

Fold-n-Seal™

Conveyor Belt Skirting System

with **WEDGE-LOC™** clamp



ARGONICS
ENGINEERED POLYURETHANE

Fold-n-Seal™

Conveyor Belt Skirt System

⚠️ WARNING ⚠️

Always obey all applicable safety rules.

Be sure all power to the conveyor has been disconnected and controls are locked out.

Installation tools required

- Tape measure
- 3/4" End Wrench and Socket
- Level
- Scribe and Chalk Line
- Welder or Drill (1/16" bit)
- Hammer
- 1" End Wrench or Crescent Wrench
- Pry Bar or Screwdriver

Parts required if bolt mounting

- Five 1/2" x 1 1/2" Grade 8 Bolt, Washer and Nuts per 5' section (not supplied)

Assembly Breakdown

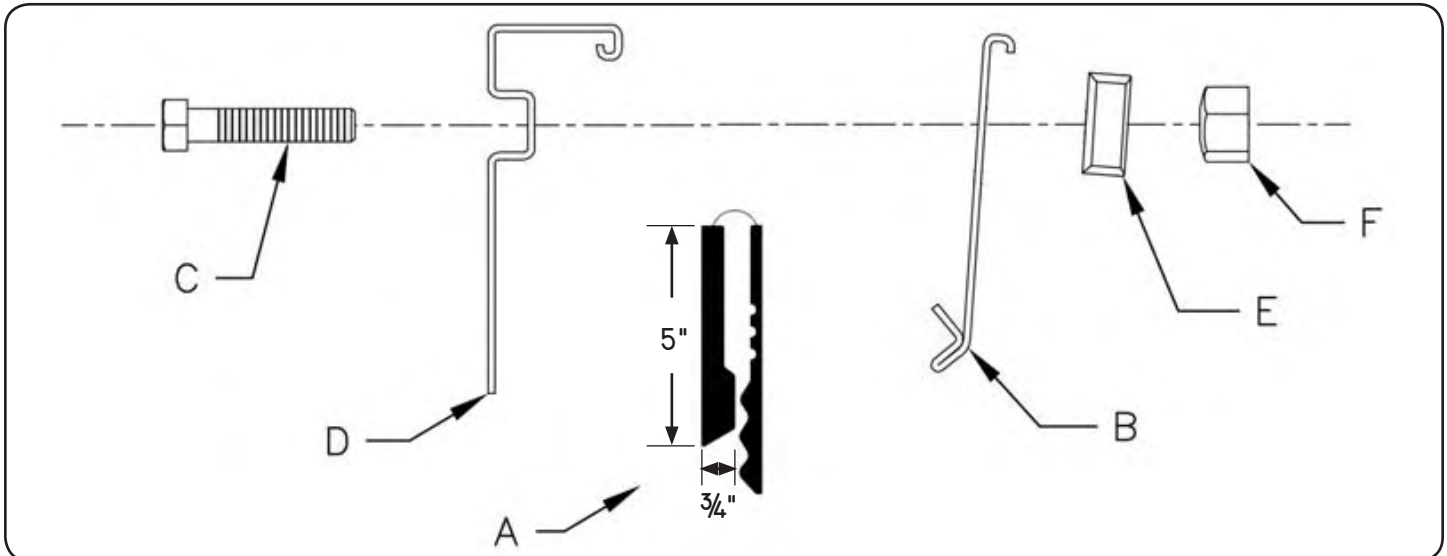

Letter	Part Number	Qty.	Description
A	CP-FS-J5"XXX"-G69	1	Fold-n-Seal multiple-seal skirt
B	CP-WL- 60C	1	Wedge Loc Arm, 12ga Galvanized, 5' section
C	BOLT-0.5x2-NC-SS	3	Stainless Steel Bolt, 1/2"-13 Unc. x 2.00 Large
D	CP-WL- 60D	1	Wedge Loc Base, 12ga Galvanized, 5' section
E	CP-WL- 35a	3	Wedge Loc Wedge
F	CP-WL- 50b	3	Brass Bowl Nut, 1/2"-13 Hex Rounded

INSTALLATION

The Fold-n-Seal conveyor belt skirting system was designed to fit most conveyor systems on the market today. The Fold-n-Seal can be installed on belt angles from 0° to 45°, and is provided with ¾" × 5" standard multiple-seal skirting. The system's belt skirt clamp assembly is shipped completely assembled in 5' sections. **If welding:** The Fold-n-Seal system requires that both the top and bottom of the base plate be welded to the chute wall for maximum support. Make sure you check the distance from the bottom of the chute wall to the belt. If this distance is greater than 1¼" you will not be able to weld to the bottom of the base plate from the front side on the Fold-n-Seal system for support. If this is the case, you will need to either add metal to the chute wall, weld the base plate from the back side or bolt the Wedge-Loc base plate into place.

Step One: Layout

Begin by making sure the power to your conveyor system is shut down and that the controls are locked out. Next, clean and remove all obstructions from the outer surface of the chute wall where you will be mounting the Fold-n-Seal system. If obstructions are non-removable, it may be necessary to cut, notch or omit the Wedge-Loc rails at specific points. This must be determined by the installer. Argonics recommends preserving the continuity of continuous clamping pressure whenever possible to achieve the best results.

At one end of the chute wall measure up 7.25" from the belt and mark the correct dimension to this point on the chute wall with a scribe. Do the same at the other end of the chute wall and then using a chalk line, snap a line from both of these marked points on the chute wall. This line marks where the top of the Wedge-Loc base plate (item D from assembly breakdown) will be placed for mounting.

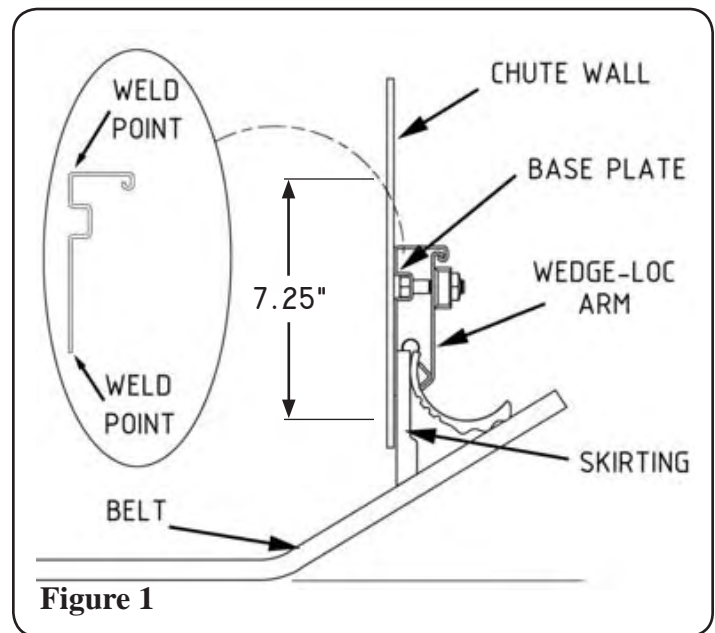

Step Two: Mounting

Next, place one 5' section of the Wedge-Loc base plate on the chute wall making sure you line up the top of the plate with the chalk line from Step One and clamp the base plate into place. Make sure that you have the supplied ½" stainless steel bolts (item C from assembly breakdown) that hold the Wedge-Loc arm in place still residing in the 2nd, 5th, 8th and 11th bolt holes (from left to right) See Figure 2 for proper placement of these bolts if they have been removed.

If bolt mounting: Use a scribe to trace the inside diameter of the 1st, 4th, 7th, 10th and 12th holes (from left to right) in the base plate (see Figure 2). Then using a ⅛" bit, drill holes in the center of the scribed outlines. Mount the base plate to the chute wall using five ½" × 1½" grade 8 bolt, washer and nuts per 5' section (not supplied). Be careful to not overtighten the bolts or warping of the base plate may occur.

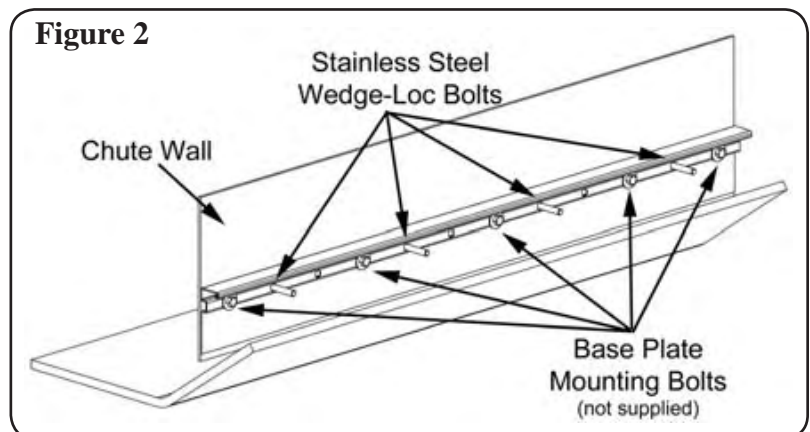

Fold-n-Seal™

Conveyor Belt Skirting System

Step Two - continued

If weld mounting: Place 2" stitch welds every 15" down the length of both the top and bottom of the base plate. Continue repeating this process with the rest of your 5' sections until your desired length is reached.

Place skirting against the back wall of the base plate with the beveled end facing away from the center of the belt and lying flush on the surface of the belt (see Figure 3). Make sure the ribbed section lays on the belt away from the center of the belt. Hook the Wedge-Loc arm (item B from assembly breakdown) into the base plate as shown in figure 1 and swing down into position over the supplied 1/2" stainless steel bolts. Next, center the wedge (item E from assembly breakdown) onto the stainless steel bolts with the wedge side facing you (flat side must be against the Wedge-Loc arm), and spin on finger tight the supplied 1/2" brass nut (item F from assembly breakdown) to the 1/2" stainless steel bolts, making sure that the convex end of the nut is facing the wedge. Repeat this process for all remaining 5' sections that you may have.

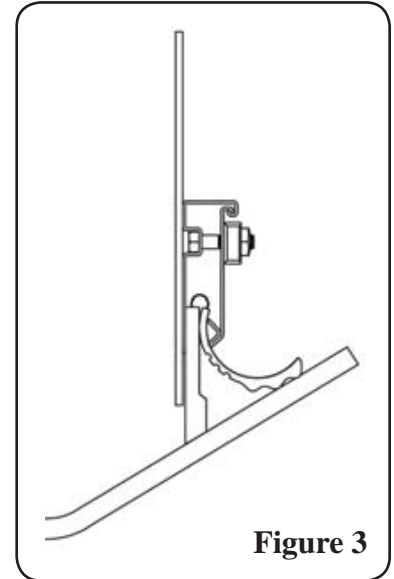

Figure 3

Step Three: Adjustment

After all sections have been installed, inspect the placement of the skirting to the belt to make sure that all the skirting is facing and seated the correct way as outlined in Step Two (also see Figure 1). Make any adjustments if necessary.

To firmly tighten the skirting into place, push downward with a pry bar/screwdriver (see Figure 5), then simply hit the high side of the wedge (see Figure 4) with a hammer. Repeat this process for all the wedges. When the skirting wears down, simply hit the low side of all the wedges per 5' section with a hammer to loosen the skirting. The skirting should automatically drop down to touch the belt. If not, pry the skirting down into place with a screwdriver so that it touches the belt (see Figure 5). Now hit the high side of the wedge with a hammer to tighten the skirting back into place.

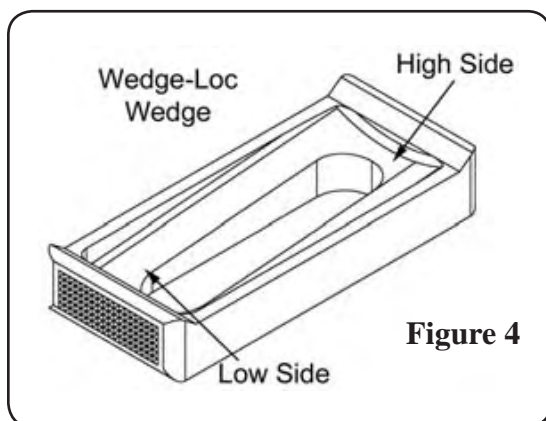

Figure 4

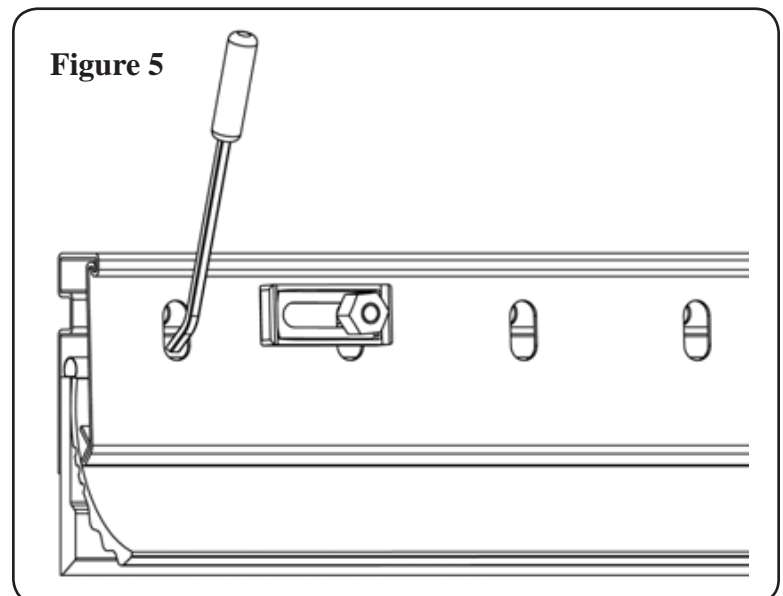

Figure 5

Your Fold-n-Seal Skirting System is now installed.