

DIAGONAL PLOW

Conveyor Belt Cleaning System

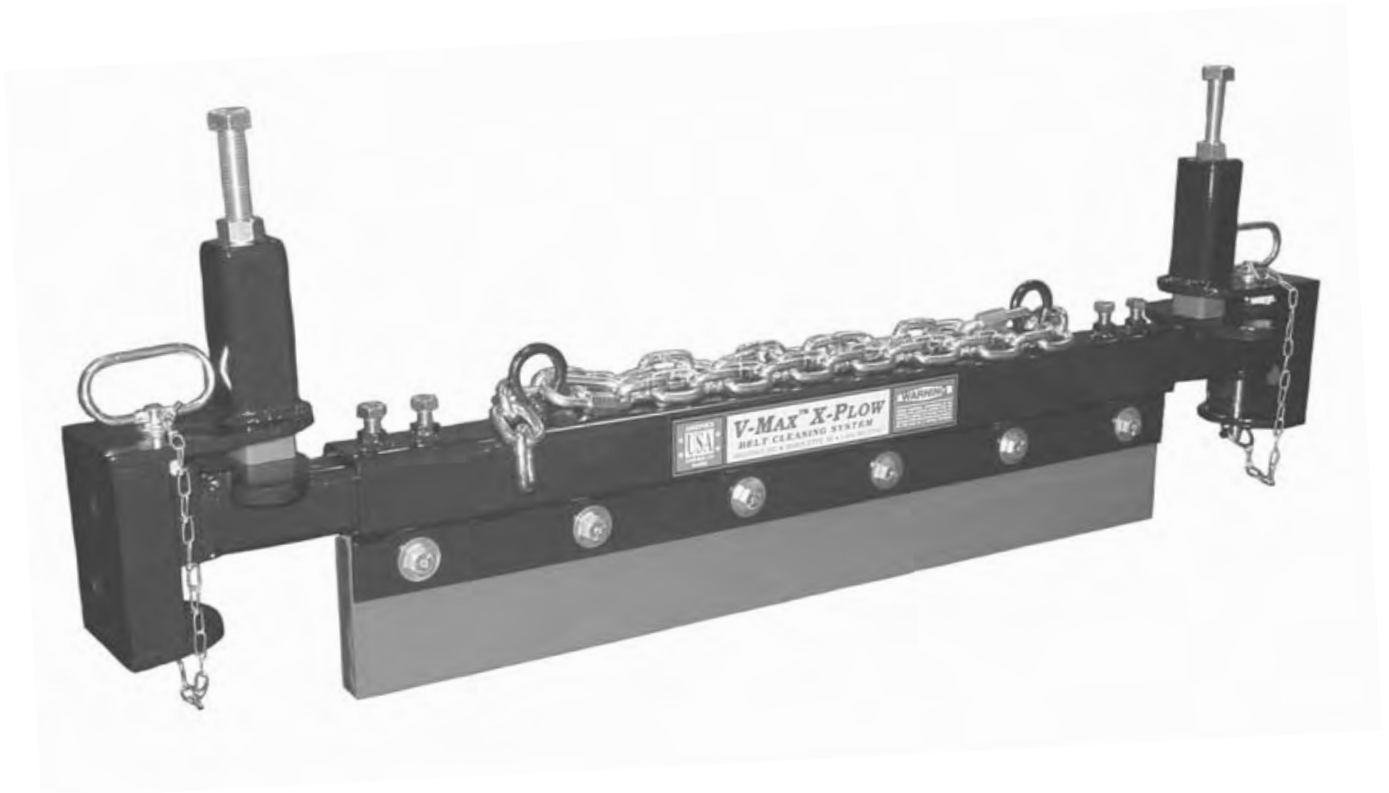

ARGONICS
ENGINEERED POLYURETHANE

DIAGONAL PLOW

Conveyor Belt Cleaning System

⚠ WARNING ⚠

Always obey all applicable safety rules.

Be sure all power to the conveyor has been disconnected and controls are locked out.

Installation Tools Required

- Tape measure
- Angle Gauge
- Level & Straight Edge
- Scribe or Chalk
- Welder or Drill
- ½" End Wrench
- 1½" End Wrench or Crescent Wrench

Bolts, lockwashers and nuts for mounting are not supplied

Assembly Breakdown

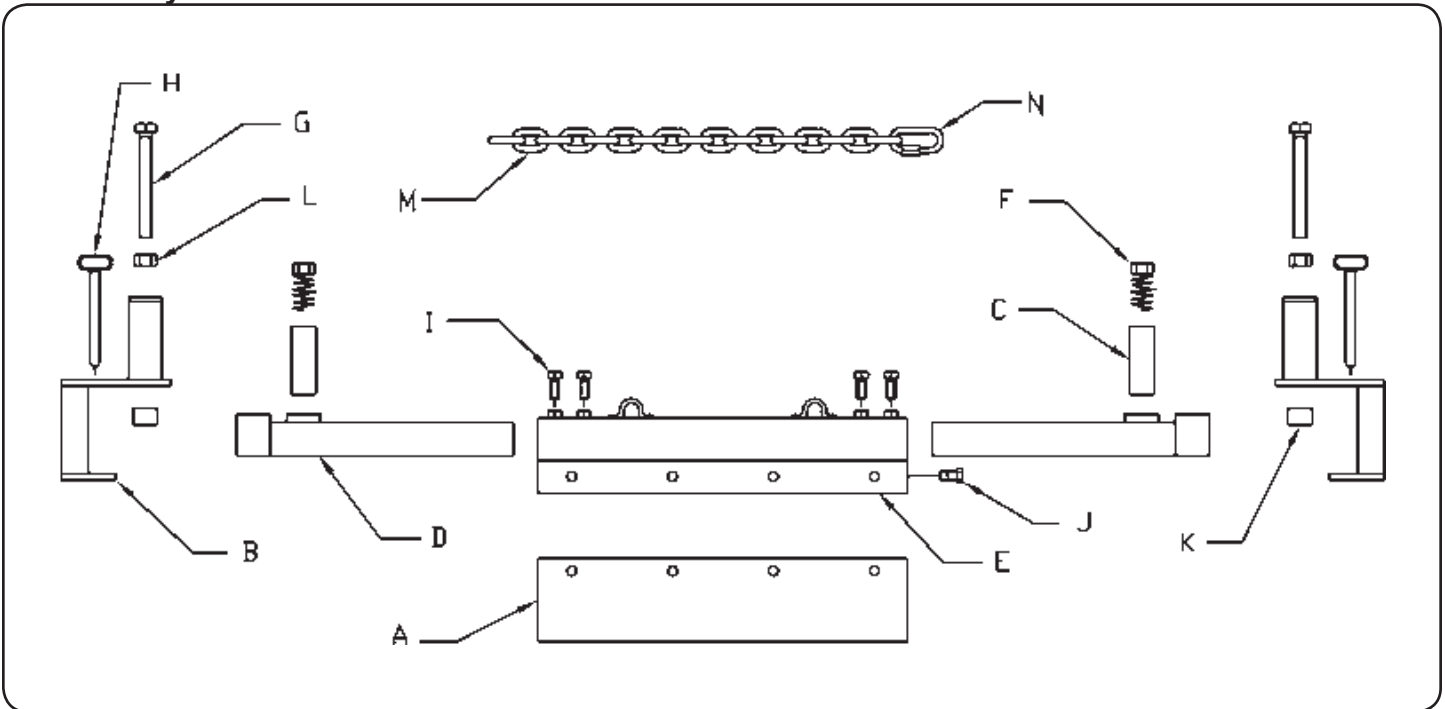

Letter	Part Number	Qty.	Description
A	CP-DP-15"xx"-G83	2	Urethane Blade, 1" × 5" × Length
B	CP-DP-3545B	2	Mounting Bracket
C	CP-XT-153-G83	2	Spring Sleeve
D	CP-DP-16.5A	2	Stub End
E	CP-DP-"xx"-"x"A	1	Mainframe
F	CP-DP-3125	2	Tension Spring
G	BOLT-0.75x6.0-NCFT	2	Tap Bolt, .75" × 6"
H	CP-AR-5006	2	Hitch Pin
I	CP-AR-5125 S	4	Stainless Hex Set Screw 1¼"
J		variable	Variable Hardware - Bolt/Washer/Nut
K	CP-XT-1515	2	Tensioner Nut, Nylon
L	NUT-0.75-10NC-BRASS	2	Brass Lock Nut, .75" NC
M	3592T34	2	Safety Chain, .375" x 24" Zinc
N	8947T18	1	Master Quick Link, ¾"

INSTALLATION

⚠ NOTICE ⚠ Safety First!

Be sure to follow all manufacturers' directions carefully. Make absolutely sure that all power sources to the conveyor you will be working on have been locked / tagged out before beginning any work.

Step One: Set Up

The Diagonal Plow is packed disassembled for shipping. Loosen the four (4) set screws on the mainframe which are holding the stub ends in place. Remove the stub ends and rotate them so that the compression platform faces up (see figure 1) and then reinsert them into the mainframe. Hand tighten the four set screws. Now unpack the mounting brackets and remove the hitch pin from each bracket. Place the mounting brackets onto the stub ends as shown in figure 1 and replace the hitch pin. The mounting brackets should be supplied with the tension spring fully retracted into the tensioner housing. If the tension spring is found to be raised to its extended position, you will need to retract the tension spring into the tensioner housing section of the mounting bracket before installing the diagonal plow. To do this, loosen the two (2) brass lock nuts and unscrew the two (2) tensioner bolts until the mounting brackets rest flush on the top of each stub end's compression platform (see figure 1 for part references).

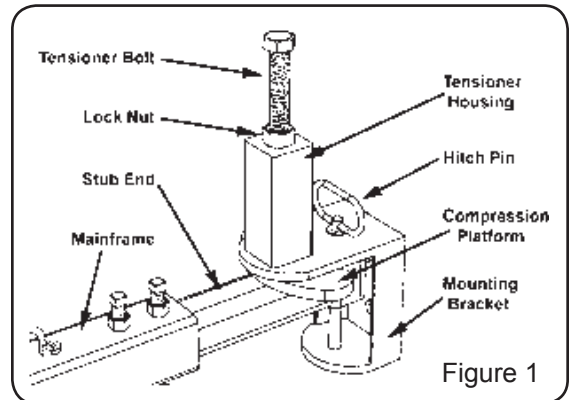
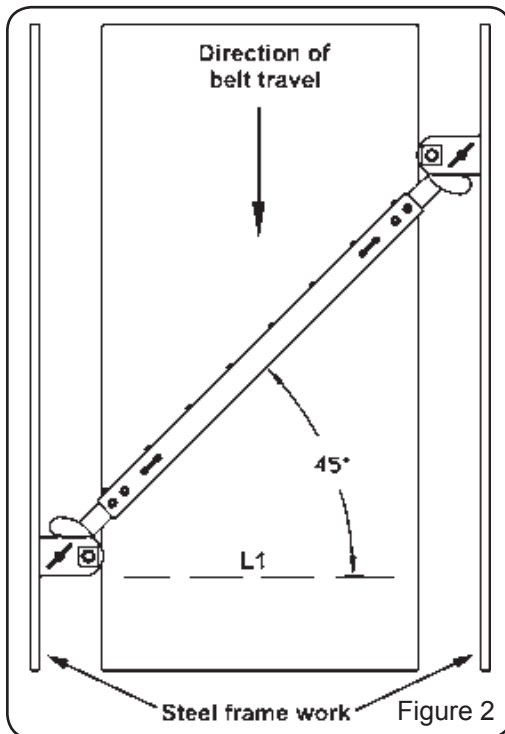

Figure 1



Step Two: Layout

Begin layout by cleaning any debris from the conveyor belt surface where you will be mounting the diagonal plow. Using a 90 degree layout tool, draw a line across the entire width of the belt perpendicular to the belt length (see L1 in figure 2). You may need to draw a partial line and then finish it with a straight edge. This line should be no further than 4 feet and no closer than 2 feet from the tail pulley in order to properly protect the pulley from tramp materials (see figure 3 on next page). If for some reason you can not mount the plow within this area, you must then mount it to the closest available flat return idler, with the distance being no more than 1 foot from the idler.

NOTE: The further you place the diagonal plow away from the tail pulley, the more likely your pulley will become susceptible to tramp materials.

The diagonal plow can be installed to discharge to the right or left of the conveyor belt and may be mounted at any angle between 25° and 45°, however we recommend an angle of 45° for proper belt cleaning. Any angle less than 25° and proper cleaning will not occur.

Using an angle layout tool, draw a diagonal line across the entire width of the belt to the angle which you desire using L1 as your reference line (see figure 2 with the reference to 45°). You may need to draw a partial line and then finish it with a straight edge.

DIAGONAL PLOW Conveyor Belt Cleaning System

Step Three: Mounting

You will need the assistance of another person to properly mount this Diagonal Plow. Start by loosening the four (4) set screws on the mainframe. Place the complete system on top of the belt surface and be sure to stand the plow upright on its blade. Make sure that the plow is parallel with the diagonal line you drew in Step 2 and that the blade is flush to the conveyor belt edge or extends beyond the belt edge on both sides. You may have

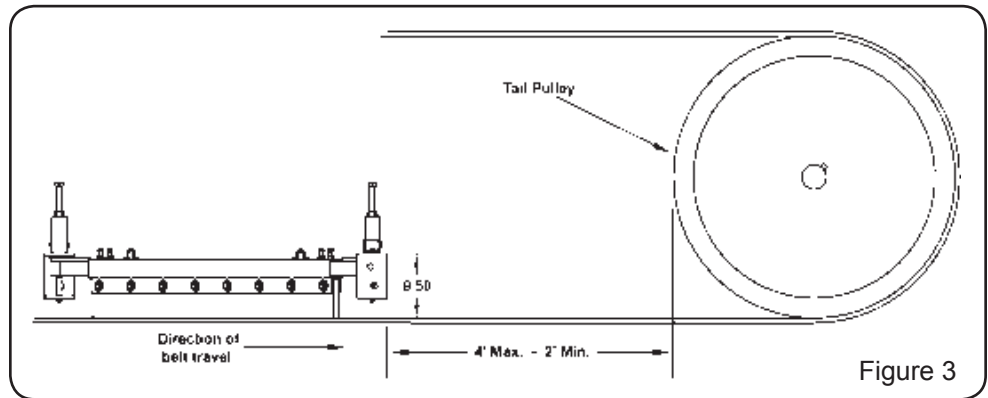

to lessen your angle in order to get the plow into this position (see figure 2). Now extend the stub ends out with the mounting bracket flush on top until they make contact with the chute wall or frame work. Trace the outline of the mounting bracket and holes onto the structure. If no chute wall or frame work is available you will need to construct an appropriate support structure. Remove the two hitch pins from both sides of the plow and set the mainframe aside. **NOTE: For Bolt In Only** - Using the traces that you made for the mounting holes, drill two $1\frac{3}{16}$ " diameter holes to accept $\frac{3}{4}$ " diameter grade 8 bolts. Now place the mounting bracket onto the structure, lining it up to the traces you made earlier and then weld or bolt into place. If welding, four stitch welds are sufficient to hold the bracket to the structure. Now place the plow back into position on the belt and reinstall the hitch pins, making sure to secure them with their safety snap pins. Retighten the set screws to secure the stub ends to the mainframe.

Step Four: Safety Chains

Safety Chains (item M on page 2) have been provided by Argonics for you and your conveyor system's safety. Weld or bolt the chain ends to the conveyor side walls approximately 6 to 8 inches in front of, and 2 to 4 inches above the plow's mainframe. When properly installed, you should have approximately 3" of slack in each chain.

NOTE: Under no circumstances should the chains ever be installed as to be touching the belt in any fashion.

If the safety chains are not installed properly, you will void any and all warranties associated with this Diagonal Plow System.

Step Five: Tensioning

Tighten the two $\frac{3}{4}$ " tensioner bolts (item G in assembly breakdown) on each mounting bracket to compress the tensioning spring $1\frac{1}{2}$ ". This will be approximately fifteen (15) revolutions to the bolt. Tighten the brass lock nuts (item L in assembly breakdown) to secure the tensioner bolt in this position. During the life of the blade, you will have to repeat this tensioning process once more.

Carefully check over the entire diagonal plow system and make sure that the two hitch pins are secured with their safety snap pins and that all bolts are secure.

Installation is now complete.