

PRICE GUIDE

LIB-CP-SYS-01-L Rev. 15

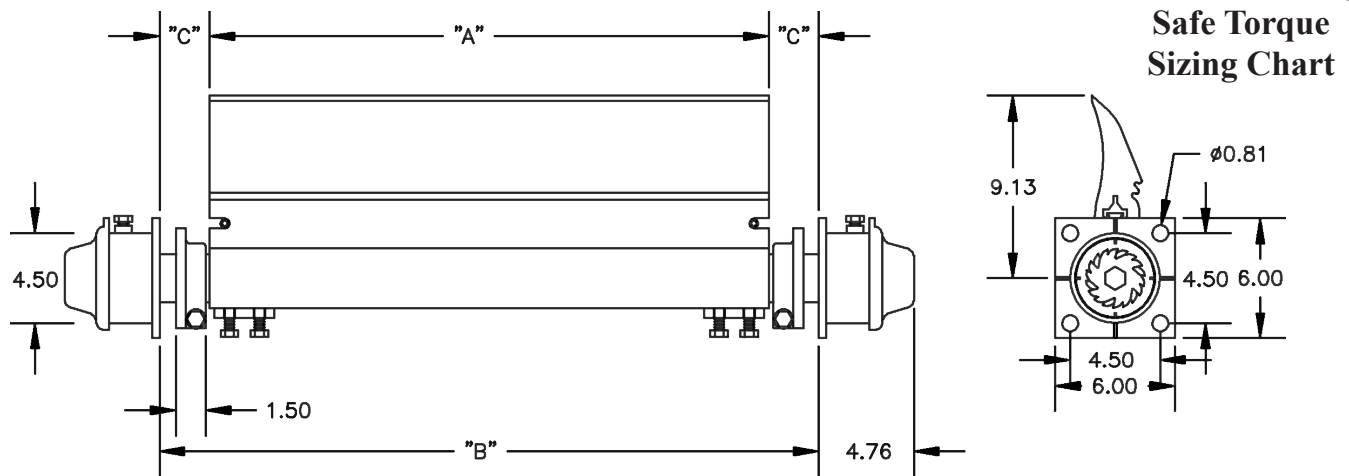

Part Number	A	Min. B	Max. B	Min. C	Max. C
CP-REA16M-G83	16.00	25.00	32.00	4.50	8.00
CP-REA18M-G83	18.00	23.00	34.00	3.00	"
CP-REA20M-G83	20.00	21.00	36.00	1.00	"
CP-REA22M-G83	22.00	22.50	38.00	0.25	"
CP-REA24M-G83	24.00	24.50	40.00	"	"
CP-REA26M-G83	26.00	26.50	42.00	"	"
CP-REA28M-G83	28.00	28.50	44.00	"	"
CP-REA30M-G83	30.00	30.50	46.00	"	"
CP-REA32M-G83	32.00	32.50	48.00	"	"
CP-REA34M-G83	34.00	34.50	50.00	"	"
CP-REA36M-G83	36.00	36.50	52.00	"	"
CP-REA38M-G83	38.00	38.50	54.00	"	"
CP-REA40M-G83	40.00	40.50	56.00	"	"
CP-REA42M-G83	42.00	42.50	58.00	"	"
CP-REA44M-G83	44.00	44.50	60.00	"	"
CP-REA46D-G83	46.00	46.50	62.00	"	"
CP-REA48D-G83	48.00	48.50	64.00	"	"
CP-REA50D-G83	50.00	50.50	66.00	"	"
CP-REA52D-G83	52.00	52.50	68.00	"	"
CP-REA54D-G83	54.00	54.50	70.00	"	"
CP-REA56D-G83	56.00	56.50	72.00	"	"
CP-REA58D-G83	58.00	58.50	74.00	"	"
CP-REA60D-G83	60.00	60.50	76.00	"	"
CP-REA62D-G83	62.00	62.50	78.00	"	"
CP-REA64D-G83	64.00	64.50	80.00	"	"
CP-REA66D-G83	66.00	66.50	82.00	"	"
CP-REA68D-G83	68.00	68.50	84.00	"	"
CP-REA70D-G83	70.00	70.50	86.00	"	"
CP-REA72D-G83	72.00	72.50	88.00	"	"
CP-REA74D-G83	74.00	74.50	90.00	"	"
CP-REA76D-G83	76.00	76.50	92.00	"	"
CP-REA78D-G83	78.00	78.50	94.00	"	"
CP-REA80D-G83	80.00	80.50	96.00	"	"
CP-REA82D-G83	82.00	82.50	98.00	"	"
CP-REA84D-G83	84.00	84.50	100.00	"	"
CP-REA86D-G83	86.00	86.50	102.00	"	"
CP-REA88D-G83	88.00	88.50	104.00	"	"
CP-REA90D-G83	90.00	90.50	106.00	"	"
CP-REA92D-G83	92.00	92.50	108.00	"	"
CP-REA94D-G83	94.00	94.50	110.00	"	"
CP-REA96D-G83	96.00	96.50	112.00	"	"

Notes:

- To get minimum B or C, Shaft Collars must be removed.
- Extended Tensioner adds 14" to B max. or 7" to C max.