

# ERASER HD™

## Sizing Chart Conveyor Belt Cleaning System

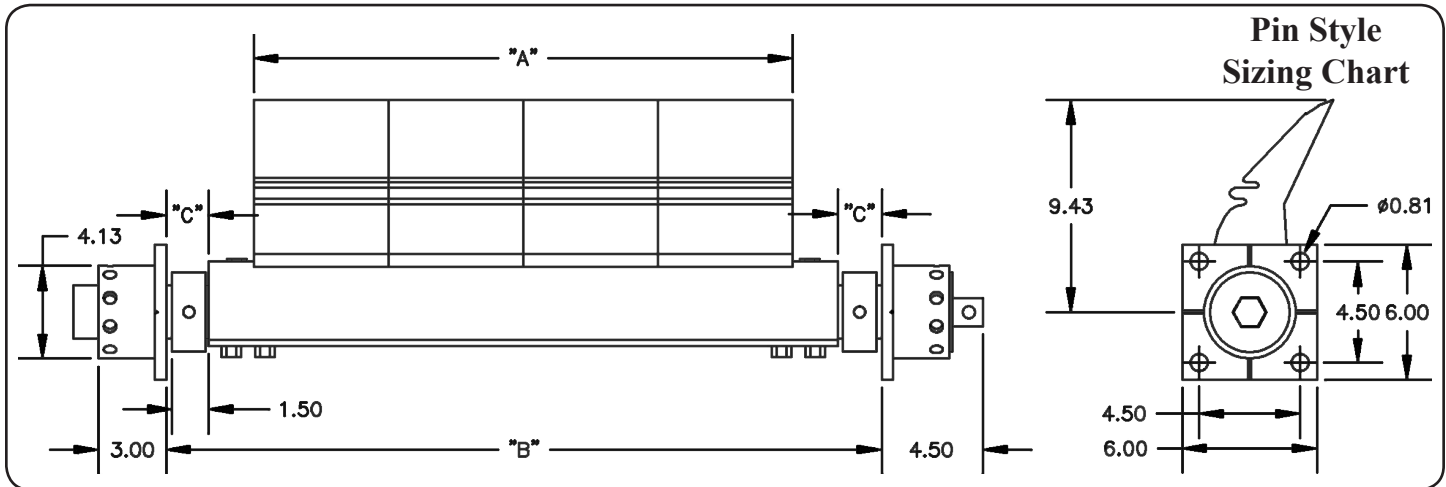

Part Number	A	Min. B	Max. B	Min. C	Max. C
CP-FET-2A16M-G83	12.00	22.50	32.00	4.50	7.00
CP-FET-3A22M-G83	18.00	22.50	38.00	0.25	"
CP-FET-4A28M-G83	24.00	28.50	44.00	"	"
CP-FET-5A34M-G83	30.00	34.50	50.00	"	"
CP-FET-6A40M-G83	36.00	40.50	56.00	"	"
CP-FET-7A46D-G83	42.00	46.50	62.00	"	"
CP-FET-8A52D-G83	48.00	52.50	68.00	"	"
CP-FET-9A58D-G83	54.00	58.50	74.00	"	"
CP-FET-10A64D-G83	60.00	64.50	80.00	"	"
CP-FET-11A70D-G83	66.00	70.50	86.00	"	"
CP-FET-12A76D-G83	72.00	76.50	92.00	"	"
CP-FET-13A82D-G83	78.00	82.50	98.00	"	"
CP-FET-14A88D-G83	84.00	88.50	104.00	"	"
CP-FET-15A94D-G83	90.00	94.50	110.00	"	"
CP-FET-16A100D-G83	96.00	100.50	116.00	"	"

**Note:**

- To get minimum B or C, Shaft Collars must be removed.
- Extended Tensioner adds 14" to B max. or 7" to C max.