

# MICRO ERASER™

Optional Safe Torque Ratchet System

Conveyor Belt Cleaning System

Sizing Chart

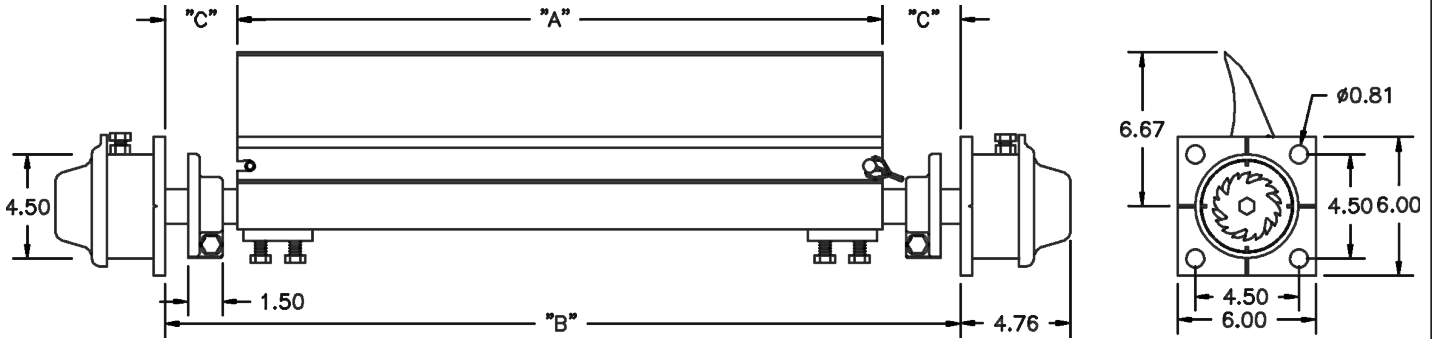

Short Tensioner (CP-MI-1350)						Standard Tensioner (CP-MI-1550)					
Part Number	A	Min. B	Max. B	Min. C	Max. C	Part Number	A	Min. B	Max. B	Min. C	Max. C
CP-JMEA16X-G83	16.00	18.00	25.50	2.00	5.00	CP-JMEA16M-G83	16.00	28.00	35.50	6.00	10.00
CP-JMEA18X-G83	18.00	18.50	27.50	0.25	"	CP-JMEA18M-G83	18.00	26.00	37.50	5.00	"
CP-JMEA20X-G83	20.00	20.50	29.50	"	"	CP-JMEA20M-G83	20.00	24.00	39.50	3.00	"
CP-JMEA22X-G83	22.00	22.50	31.50	"	"	CP-JMEA22M-G83	22.00	22.50	41.50	1.00	"
CP-JMEA24X-G83	24.00	24.50	33.50	"	"	CP-JMEA24M-G83	24.00	24.50	43.50	"	"
CP-JMEA26X-G83	26.00	26.50	35.50	"	"	CP-JMEA26M-G83	26.00	26.50	45.50	"	"
CP-JMEA28X-G83	28.00	28.50	37.50	"	"	CP-JMEA28M-G83	28.00	28.50	47.50	"	"
CP-JMEA30X-G83	30.00	30.50	39.50	"	"	CP-JMEA30M-G83	30.00	30.50	49.50	"	"
CP-JMEA32X-G83	32.00	32.50	41.50	"	"	CP-JMEA32M-G83	32.00	32.50	51.50	"	"
CP-JMEA34X-G83	34.00	34.50	43.50	"	"	CP-JMEA34M-G83	34.00	34.50	53.50	"	"
CP-JMEA36Z-G83	36.00	36.50	45.50	"	"	CP-JMEA36D-G83	36.00	36.50	55.50	"	"
CP-JMEA38Z-G83	38.00	38.50	47.50	"	"	CP-JMEA38D-G83	38.00	38.50	57.50	"	"
CP-JMEA40Z-G83	40.00	40.50	49.50	"	"	CP-JMEA40D-G83	40.00	40.50	59.50	"	"
CP-JMEA42Z-G83	42.00	42.50	51.50	"	"	CP-JMEA42D-G83	42.00	42.50	61.50	"	"
CP-JMEA44Z-G83	44.00	44.50	53.50	"	"	CP-JMEA44D-G83	44.00	44.50	63.50	"	"
CP-JMEA46Z-G83	46.00	46.50	55.50	"	"	CP-JMEA46D-G83	46.00	46.50	65.50	"	"
CP-JMEA48Z-G83	48.00	48.50	57.50	"	"	CP-JMEA48D-G83	48.00	48.50	67.50	"	"
CP-JMEA50Z-G83	50.00	50.50	59.50	"	"	CP-JMEA50D-G83	50.00	50.50	69.50	"	"
CP-JMEA52Z-G83	52.00	52.50	61.50	"	"	CP-JMEA52D-G83	52.00	52.50	71.50	"	"
CP-JMEA54Z-G83	54.00	54.50	63.50	"	"	CP-JMEA54D-G83	54.00	54.50	73.50	"	"
CP-JMEA56Z-G83	56.00	56.50	65.50	"	"	CP-JMEA56D-G83	56.00	56.50	75.50	"	"
CP-JMEA58Z-G83	58.00	58.50	67.50	"	"	CP-JMEA58D-G83	58.00	58.50	77.50	"	"
CP-JMEA60Z-G83	60.00	60.50	69.50	"	"	CP-JMEA60D-G83	60.00	60.50	79.50	"	"
CP-JMEA62Z-G83	62.00	62.50	71.50	"	"	CP-JMEA62D-G83	62.00	62.50	81.50	"	"
CP-JMEA64Z-G83	64.00	64.50	73.50	"	"	CP-JMEA64D-G83	64.00	64.50	83.50	"	"
CP-JMEA66Z-G83	66.00	66.50	75.50	"	"	CP-JMEA66D-G83	66.00	66.50	85.50	"	"
CP-JMEA68Z-G83	68.00	68.50	77.50	"	"	CP-JMEA68D-G83	68.00	68.50	87.50	"	"
CP-JMEA70Z-G83	70.00	70.50	79.50	"	"	CP-JMEA70D-G83	70.00	70.50	89.50	"	"
CP-JMEA72Z-G83	72.00	72.50	81.50	"	"	CP-JMEA72D-G83	72.00	72.50	91.50	"	"

Notes:

- To get minimum B or C, Shaft Collars must be removed and one stub end might have to cut.
- On Short Blade/Long Frame Systems the Mainframe length must be a minimum 4" longer than the actual blade width selected.