

Technical Product Bulletin

Salt & Sand Spreaders

Polyurethane Salt/Sand Spreader by Argonics

Our Salt & Sand Spreader, with its straight fins, fits most truck equipment on the market. A metal insert with several pre-made mounting holes has a universal design to mount with common hub assemblies.

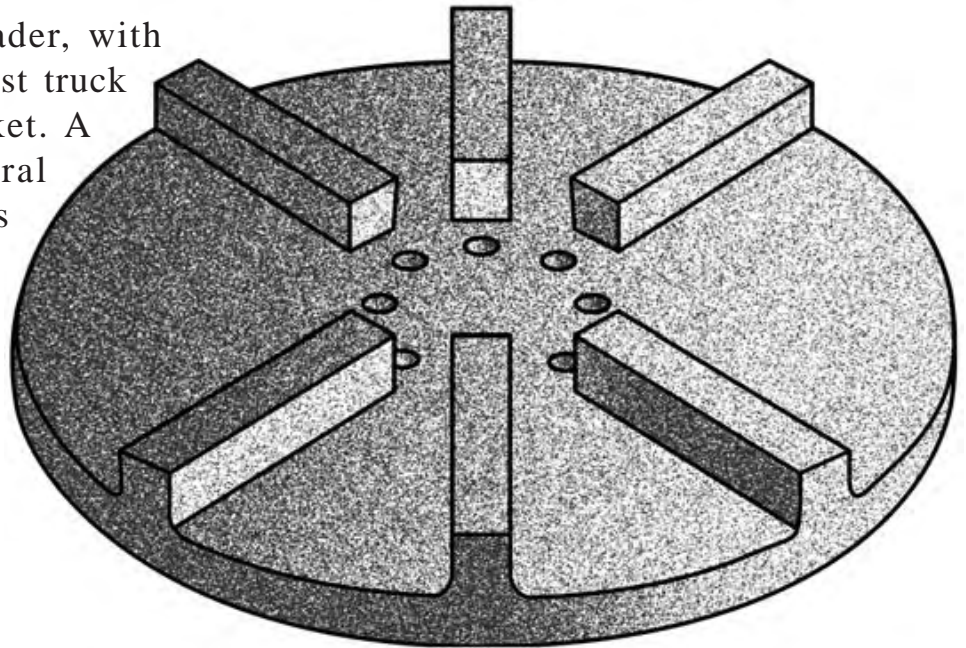

ADVANTAGES OVER STEEL INCLUDE:

- Abrasion resistance is many times better than steel.
- Light weight which is easier for maintenance to handle and needs less horsepower to turn.
- Corrosion resistance so salt & sand will not cause rust problems.
- Non-stick surface prevents build-up of frozen sand, which causes improper spreading.
- Flexible – they do not bend or break when hit.

ADVANTAGES OVER OTHER PLASTICS AND URETHANES INCLUDE:

- More flexible than hard plastics, which can be cracked when hit.
- Better abrasion resistance against all plastics and competitors urethanes, proven in actual usage in the snowiest areas of the United States. Performance results show four times the life over two of the leading brands of spreaders on the market.



ARGONICS
ENGINEERED POLYURETHANE

520 9th St. • Gwinn, MI 49841 USA • Phone: 906.226.9747 1.800.991.2746 Fax: 906.226.9779