

Technical Product Bulletin

SNAP-LOC™

DUST SEAL SYSTEM

- High Performance Argonics Polyurethane
- MSHA accepted flame retardant formulas available
- Quick weld or bolt-in installation
- Easy maintenance
- Available in continuous lengths up to 60'
- Reduces friction by 60% compared to rubber seals
- Solid galvanized steel mounting rail
- Tear resistant 3/8" thick construction
- Stops material loss dead in its tracks

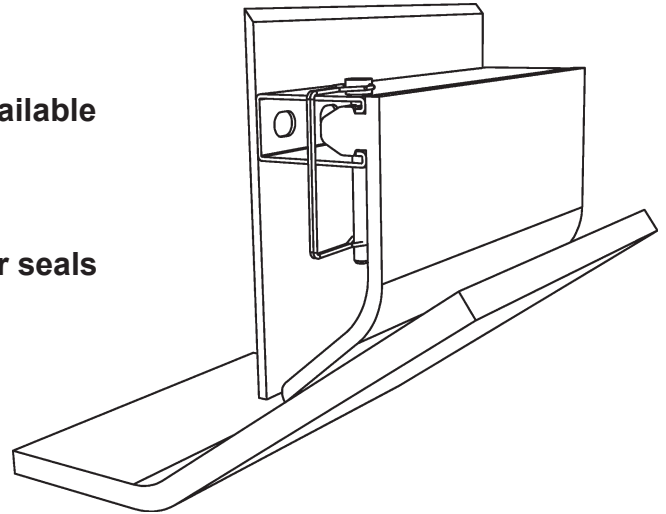

Breathe Easier... With SNAP-LOC™!

Our Snap-Loc™ Dust Seal is a straightforward, simple solution to dust containment and control. Its unique maintenance friendly design installs quickly and easily into most conveyor systems. Simply tack weld the mounting rail to your system, snap the dust seal into place, then just pin it and forget it. Later replacement of worn dust seals is a *snap* because of our folded steel lip mounting rail and Snap-Loc dust seal design.

The Snap-Loc Dust Seal utilizes our exclusive High Performance Polyurethane which stands up to the harshest environments. Snap-Loc Dust Seal utilizes our urethane's inherent "memory-set" to apply downward pressure onto the belt's surface to create a fines-tight seal. This seal will continue to self-adjust throughout the life of the dust seal, so there is no need for manual adjustment.

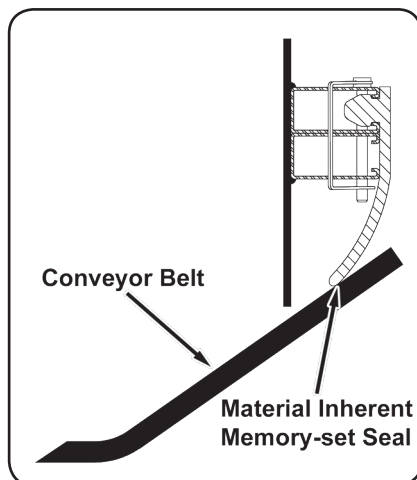

Snap-Loc Dust Seal is also very cost-effective, producing 60% less drag on your conveyor belt system than equivalent rubber seals on the market today. This vastly improves start-up conditions and adds life to all your major components, saving you money and down time.

Combine this with our Wedge-Loc™ Skirting System, Snap-Loc™ Dust Curtain and LOAD ZONE™ Support systems, and you have a high performance, economically priced solution to dust containment.

Snap-Loc™, Wedge-Loc™ and LOAD ZONE™ are trademarks of Argonics, Inc. Gwinn, MI. USA

Argonics, Inc. • 520 9th Street • Gwinn, MI 49841 USA • Phone: 906.226.9747 800.991.2746 Fax: 906.226.9779

LIB-CP-SL-04-01 Rev. 2