

PRICE GUIDE

LIB-CP-SYS-01-L Rev. 15

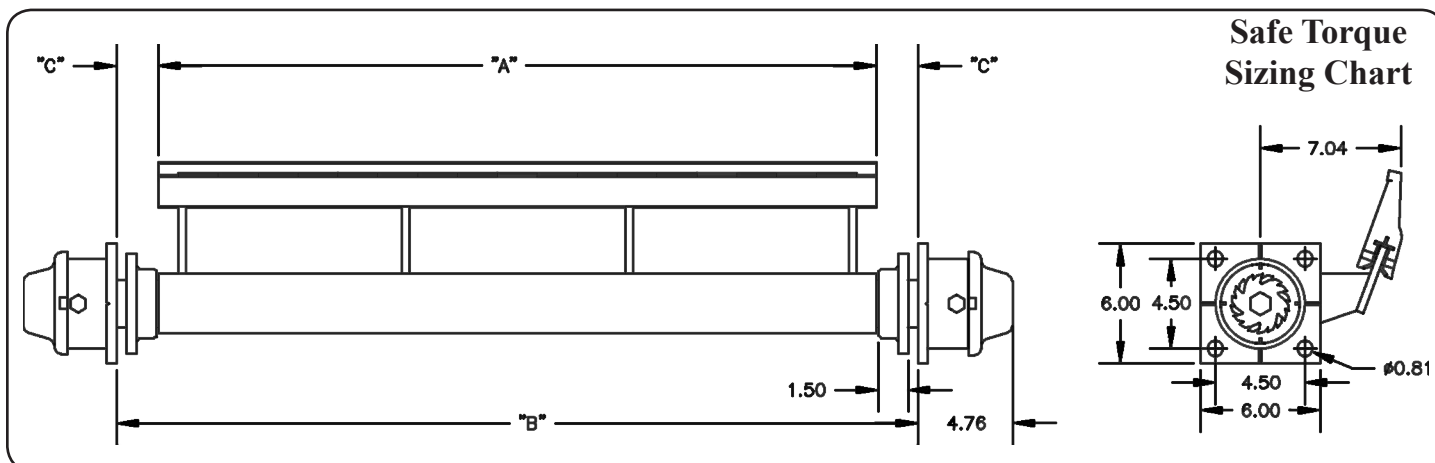

Part Number	A	Min. B	Max. B	Min. C	Max. C
CP-ESG16M-G83	16.00	25.00	35.00	4.50	10.00
CP-ESG18M-G83	18.00	23.00	37.00	2.50	"
CP-ESG20M-G83	20.00	21.00	39.00	0.50	"
CP-ESG22M-G83	22.00	22.50	41.00	0.25	"
CP-ESG24M-G83	24.00	24.50	43.00	"	"
CP-ESG26M-G83	26.00	26.50	45.00	"	"
CP-ESG28M-G83	28.00	28.50	47.00	"	"
CP-ESG30M-G83	30.00	30.50	49.00	"	"
CP-ESG32M-G83	32.00	32.50	51.00	"	"
CP-ESG34M-G83	34.00	34.50	53.00	"	"
CP-ESG36M-G83	36.00	36.50	55.00	"	"
CP-ESG38M-G83	38.00	38.50	57.00	"	"
CP-ESG40M-G83	40.00	40.50	59.00	"	"
CP-ESG42M-G83	42.00	42.50	61.00	"	"
CP-ESG44M-G83	44.00	44.50	63.00	"	"
CP-ESG46D-G83	46.00	46.50	65.00	"	"
CP-ESG48D-G83	48.00	48.50	67.00	"	"
CP-ESG50D-G83	50.00	50.50	69.00	"	"
CP-ESG52D-G83	52.00	52.50	71.00	"	"
CP-ESG54D-G83	54.00	54.50	73.00	"	"
CP-ESG56D-G83	56.00	56.50	75.00	"	"
CP-ESG58D-G83	58.00	58.50	77.00	"	"
CP-ESG60D-G83	60.00	60.50	79.00	"	"
CP-ESG62D-G83	62.00	62.50	81.00	"	"
CP-ESG64D-G83	64.00	64.50	83.00	"	"
CP-ESG66D-G83	66.00	66.50	85.00	"	"
CP-ESG68D-G83	68.00	68.50	87.00	"	"
CP-ESG70D-G83	70.00	70.50	89.00	"	"
CP-ESG72D-G83	72.00	72.50	91.00	"	"
CP-ESG74D-G83	74.00	74.50	93.00	"	"
CP-ESG76D-G83	76.00	76.50	95.00	"	"
CP-ESG78D-G83	78.00	78.50	97.00	"	"
CP-ESG80D-G83	80.00	80.50	99.00	"	"
CP-ESG82D-G83	82.00	82.50	101.00	"	"
CP-ESG84D-G83	84.00	84.50	103.00	"	"
CP-ESG86D-G83	86.00	86.50	105.00	"	"
CP-ESG88D-G83	88.00	88.50	107.00	"	"
CP-ESG90D-G83	90.00	90.50	109.00	"	"
CP-ESG92D-G83	92.00	92.50	111.00	"	"
CP-ESG94D-G83	94.00	94.50	113.00	"	"
CP-ESG96D-G83	96.00	96.50	115.00	"	"

Notes:

- To get minimum B or C, Shaft Collars must be removed.
- Extended Tensioner adds 14" to B max. or 7" to C max.