

SUPER HD ERASER™

Primary Conveyor Belt Cleaning System



ARGONICS
ENGINEERED POLYURETHANE

SUPER HD ERASER™

Primary Conveyor Belt Cleaning System

▲ WARNING ▲

Always obey all applicable safety rules. Be sure all power to the conveyor has been disconnected and controls are locked out.

Installation Tools Required

- Tape measure
- Cutting Torch or Hole Saw (4")
- Level
- Scribe or Chalk
- Welder or Drill
- ½" End Wrench
- 1¼" End Wrench or Crescent Wrench

ASSEMBLY BREAKDOWN

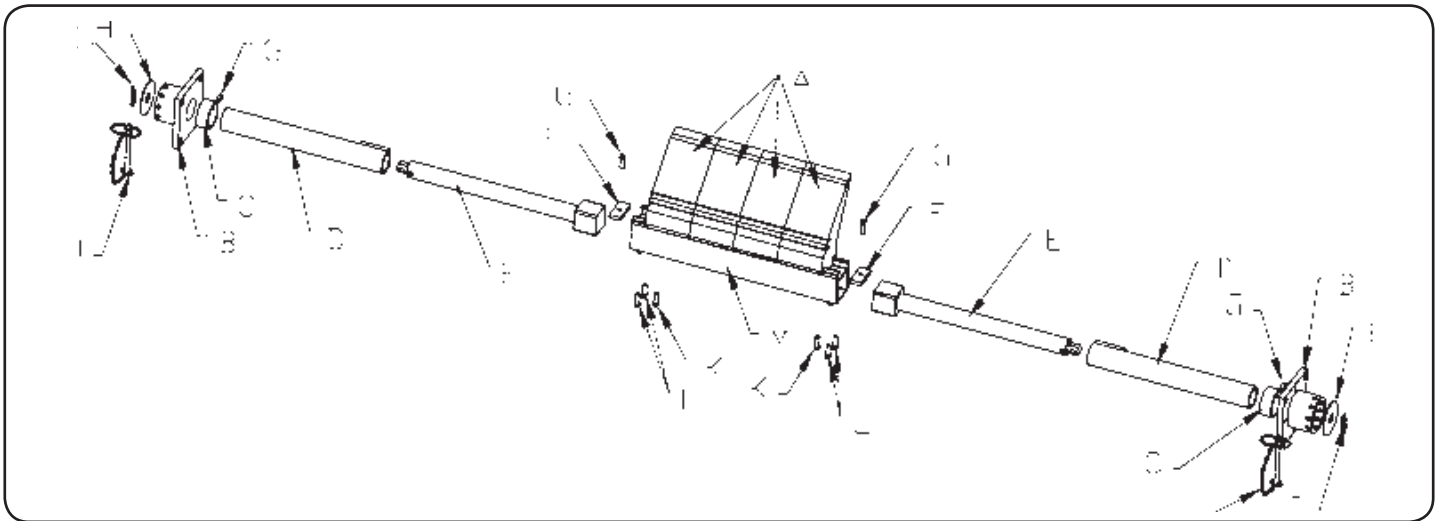

Letter	Part Number	Qty.	Description
A	CP-MEX-"xx"-G83	Varies	Heavy Duty Raptor Blade
B	CP-SE-77-DA-B93	2	Mounting Spool
C	CP-SE-283-C	2	Locking Collar
D	CP-SE-22-B	2	Stub End
E*	CP-SE-2050-E-B93	1	Perma-Torque Tensioner
F	CP-AR-154	2	Heavy Duty Retainer Clip
G	CP-AR-5075	2	Square Head Set Screw ½" x ¾"
H*	CP-SE-85-F	1	Retainer Washer
I*	CP-AR-4125	1	Self-Locking Twist Pin
J*	CP-AR-5006	1	Tension Pin
K	CP-AR-5125	2	Square Head Set Screw ½" x 1¼"
L	CP-AR-5150	6	Square Head Set Screw ½" x 1½"
M	CP-ST-"xx"A	1	Mainframe

* Systems 34" and above come standard with dual tensioners and require two (2) of each of the noted parts.

INSTALLATION

Note:

This Super HD Eraser Primary Belt Cleaning System is designed to be used on conveyor pulleys of 12" in radius (24" in diameter) and larger. Using this system on a pulley smaller than the recommended size stated above will not provide proper cleaning of your conveyor system.

Dimension Table

Outside Radius	X	Z
12" - 14"	7½"	15¼"
14½" - 15½"	7"	15¼"
16" - 17½"	6½"	15¼"
18" - 20"	6"	15¼"
20½" - 22½"	5½"	15¼"
23" - 24½"	5¾"	15¼"
25" and Larger	5"	15¼"

Step One: Calculations

Measure the distance from the center of your pulley shaft to the outside surface of your conveyor belt. This will be your Outside Radius ("A" on the illustration below). Find your Outside Radius on the Dimension Table to the left. Add the corresponding "X" dimension to your Outside Radius. (Example: 14" Radius + 7½" = 21½"). This is your "Y" dimension (Y = 21½"). The illustrated "Z" dimension is a minimum value and provides for the optimum mounting position.

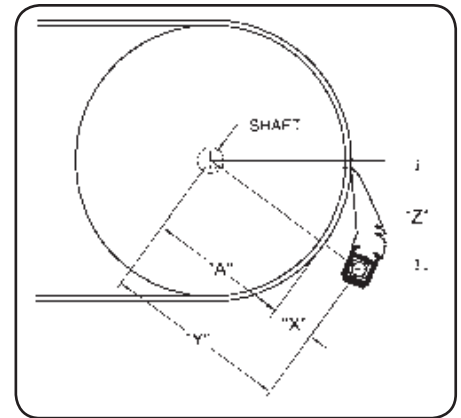

Step Two: Layout

From the center of the pulley shaft, scribe an arc (equal to your "Y" dimension) on the outside of the mounting structure wall. Then measure down from the center of the pulley shaft using the "Z" dimension, and using a level, scribe a horizontal line across the mounting structure that intersects the arc at "Y". Using a level and scribe, draw a vertical line approximately 8" long which bisects the horizontal line at the intersection. This bisected point will be the center point for the mounting spool location. If no structure is available at this point, metal will need to be added.

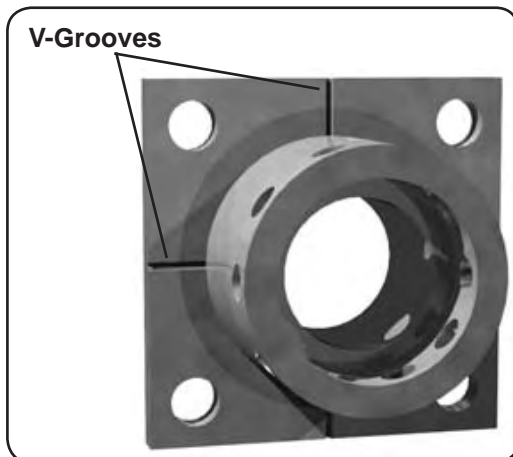

The Super HD Eraser System comes fully assembled. Remove the mounting spools from the system. The mounting spools are designed to be welded or bolted into position. Using a mounting spool as a template, line up the centering V-grooves machined into the flange of the mounting spool with the bisected horizontal and vertical lines on the mounting structure wall.

Trace the inside diameter of the spool and the entire perimeter of the square flange to the mounting structure wall. Also, transfer the bolt hole pattern if you intend to bolt the system into place rather than weld. Repeat this Step Two process for the other side of the mounting structure.

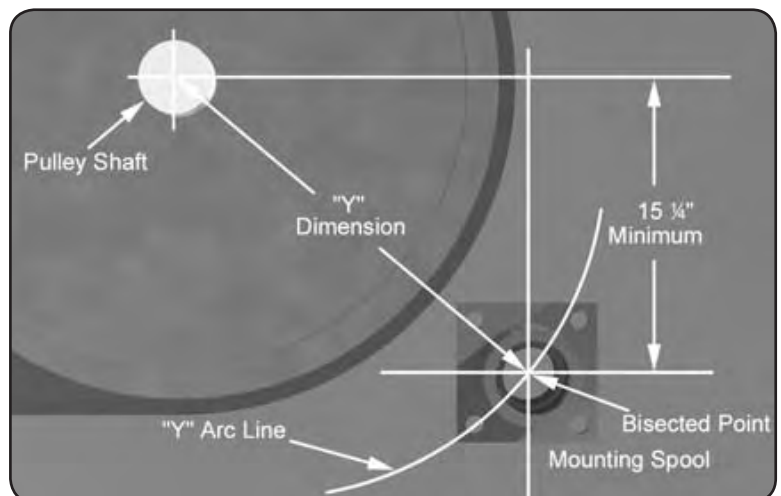

SUPER HD ERASER™

Primary Conveyor Belt Cleaning System

Step Three: Mounting

Cut the center hole with approximately a $\frac{5}{8}$ " larger radius than the trace which was scribed on each side of the mounting structures (your hole should be approx. 4" in diameter). **NOTE: For Bolt In Only** - Using the traces that you scribed for the mounting holes, drill four $\frac{13}{16}$ " diameter holes to accept $\frac{3}{4}$ " diameter grade 8 bolts. Place the mounting spool onto the side of the mounting structure wall. Use the scribed perimeter lines to line up the spool and then weld or bolt it into place. If welding, four stitch welds is sufficient on the flats of the mounting spool. Using a $\frac{1}{2}$ " end wrench, loosen the (3) square head set screws at each end of the mainframe. Remove the stub end pipes (and tensioner assembly) from the mainframe. Loosen the locking collar set screw and collapse unit as fully as possible. Lift the mainframe into position. Telescope the stub ends and slide tensioner assembly through the holes in the mounting structure. Temporarily install tension pin through mounting spool. Center the blade with the belt and snug the mainframe set screws to secure the stub ends. Snug locking collars to inside wall and cinch the set screw. Check for free rotation, minimal lateral movement of the assembly shaft, and consistent contact of the blade to the belt. Adjust if necessary, realign, and tighten all mainframe set screws.

▲ WARNING ▲

When tensioning be sure to keep body clear of the tensioner path.

Step Four: Tensioning

The Super HD Eraser System is provided with our exclusive totally internal Perma-Torque Tensioner. The Perma-Torque is an adjustable elastomeric tensioner. The tensioner may be adjusted from a recommended minimum force of 65 foot pounds, to a maximum 127 foot pounds. Exceeding tensioning of 12 holes or 432° will damage the tensioner. Five holes or 180° is our standard setting, which is recommended for most applications. To tension, first remove the tensioning pin, then use a $1\frac{1}{4}$ " end wrench on the exposed hex bar. Turn the tensioner towards the pulley. When you have reached the desired rating, replace the tensioning pin. The $\frac{5}{8}$ " diameter hole in the hex bar will be in line with the holes in the mounting spool and the hole in the tensioner. This helps to align the tensioning pin. You may optionally choose to use a crescent wrench, pipe wrench, large screwdriver or pry bar in place of the $1\frac{1}{4}$ " end wrench.

Tensioning Guide		
No. of holes	Degrees	Foot Pounds
2	72°	47
3	108°	65
*5	180°	80
6	216°	85
8	288°	110
10	360°	120
12	432°	127

Do Not Overtension
* 180° is our standard which is recommended for most applications.

Installation is now complete.

Maintenance or retensioning should not be required throughout the life of the blade.