

SUPER HD ERASER™

Sizing Chart Conveyor Belt Cleaning System

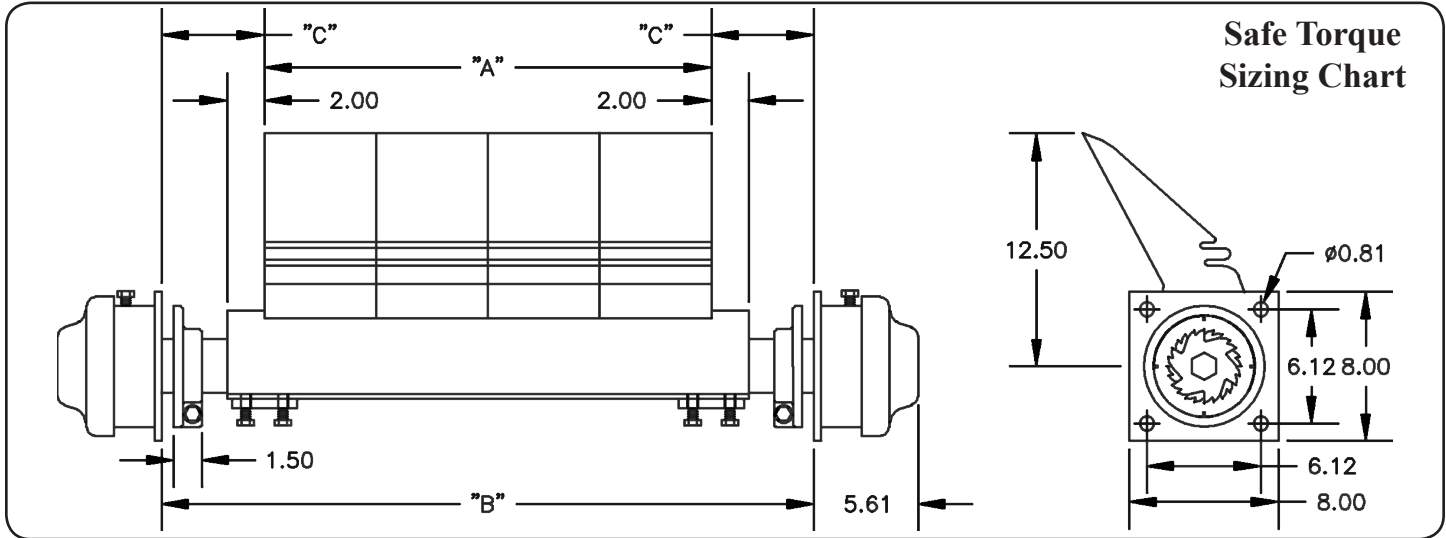

Part Number	A	Min. B	Max. B	Min. C	Max. C
CP-ST-4A28M-G83	24.00	28.50	58.00	0.25	16.50
CP-ST-5A34D-G83	30.00	44.50	64.00	7.25	"
CP-ST-6A40D-G83	36.00	44.50	70.00	4.25	"
CP-ST-7A46D-G83	42.00	46.50	76.00	1.25	"
CP-ST-8A52D-G83	48.00	52.50	82.00	0.25	"
CP-ST-9A58D-G83	54.00	58.50	88.00	"	"
CP-ST-10A64D-G83	60.00	64.50	94.00	"	"
CP-ST-11A70D-G83	66.00	70.50	100.00	"	"
CP-ST-12A76D-G83	72.00	76.50	106.00	"	"
CP-ST-13A82D-G83	78.00	82.50	112.00	"	"
CP-ST-14A88D-G83	84.00	88.50	118.00	"	"
CP-ST-15A94D-G83	90.00	94.50	124.00	"	"
CP-ST-16A100D-G83	96.00	100.50	130.00	"	"
CP-ST-17A106D-G83	102.00	106.50	136.00	"	"
CP-ST-18A112D-G83	108.00	112.50	142.00	"	"
CP-ST-19A118D-G83	114.00	118.50	148.00	"	"

Note:

- To get minimum B or C, Shaft Collars must be removed.