

# Eraser PQ™

## PRIMARY CONVEYOR BELT CLEANING SYSTEM

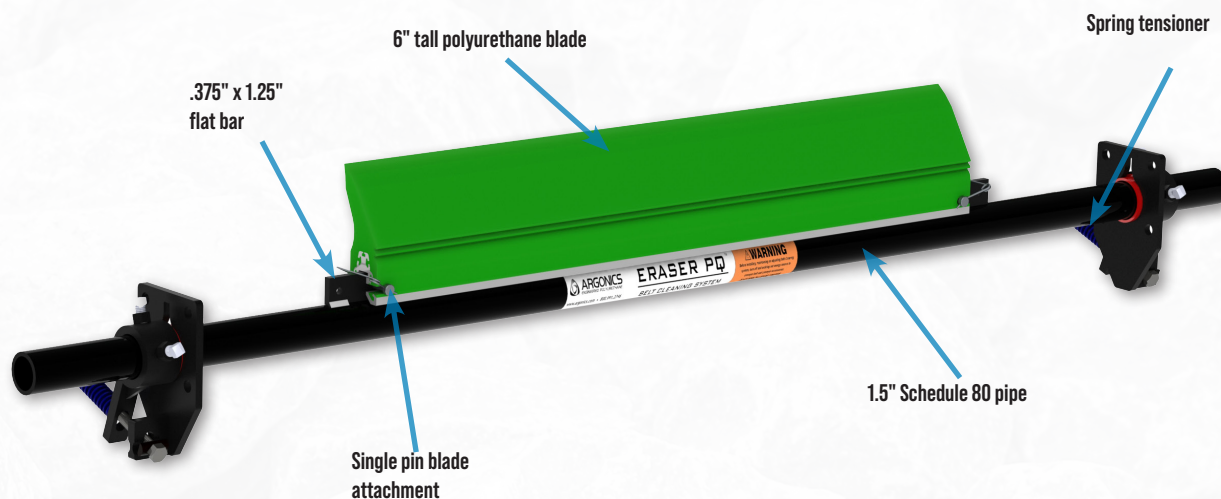

The Eraser PQ (Pit and Quarry) system is an economical cleaner designed for performance and reliability. With a simple and effective spring tensioning unit, it uses our 6" tall blade and requires little to no maintenance.



### BENEFITS:

- Ideally suited for pit and quarry applications
- Economical yet designed for performance and reliability
- Effective cleaning performance with a 6" (152 mm) tall polyurethane blade
- Easy to install and tension and requires little to no maintenance.
- Offers a simple and effective spring tensioning unit - keeping consistent pressure against the conveyor belt
- Single pin blade attachment means quick and simple blade change out with less downtime

### BLADES:

- |  |   |
|--|---|
|  <b>N62 Ether</b><br>Normally used for extremely wet applications, sands & fines      |  <b>B93 Ester</b><br>Our high temperature cleaning blade, up to 250°F (121°C)  |
|  <b>R80 Ether</b><br>Good for wet applications with any pH level                      |  <b>FO83 Ester</b><br>MSHA approved Front Line® flame-retardant cleaning blade |
|  <b>G83 Ester</b><br>Our standard, high abrasion-resistant all-purpose cleaning blade |  <b>RU83 Ester</b><br>Flame retardant, anti-static cleaning blade              |
|  <b>U90</b><br>Good for dry applications with any pH level                            |   |



# SIZING INFORMATION

Dimensions - in. (mm)

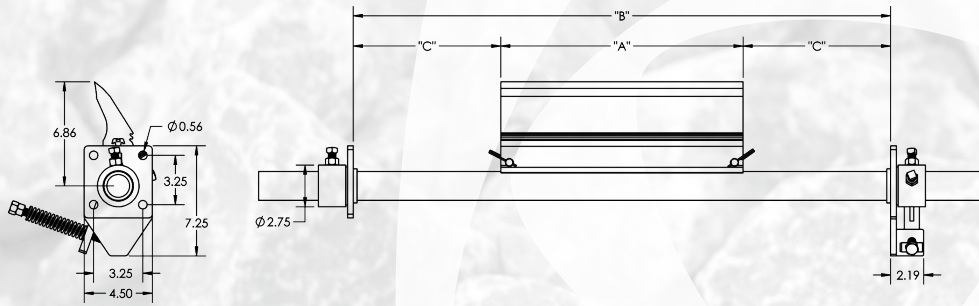

Part Number	A		Min B		Max B		Min C		Max C	
	inches	(mm)	inches	(mm)	inches	(mm)	inches	(mm)	inches	(mm)
CP-PQ-A1218M-G83	12.00	(305)	18.00	(458)	41.00	(1042)	3.00	(77)	14.50	(367)
CP-PQ-A1824M-G83	18.00	(458)	24.00	(610)	47.00	(1194)	3.00	(77)	14.50	(367)
CP-PQ-A2430M-G83	24.00	(610)	30.00	(876)	53.00	(1347)	3.00	(77)	14.50	(367)
CP-PQ-A3036M-G83	30.00	(762)	36.00	(915)	59.00	(1499)	3.00	(77)	14.50	(367)
CP-PQ-A3642D-G83	36.00	(915)	42.00	(1067)	65.00	(1651)	3.00	(77)	14.50	(367)
CP-PQ-A4248D-G83	42.00	(1067)	48.00	(1220)	71.00	(1084)	3.00	(77)	14.50	(367)
CP-PQ-A4854D-G83	48.00	(1220)	54.00	(1372)	77.00	(1956)	3.00	(77)	14.50	(367)
CP-PQ-A5460D-G83	54.00	(1372)	60.00	(1524)	83.00	(2109)	3.00	(77)	14.50	(367)

## SPECIFICATIONS

Recommended Belt Speeds  
0 - 450 fpm (2.29 m/s)

Pulley Diameter (PD)  
Minimum: 8" (203 mm)  
Maximum: 20" (508 mm)

## MOUNTING INFORMATION

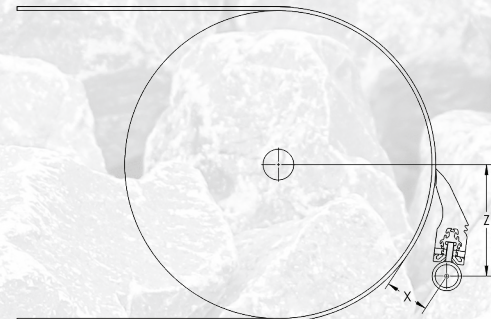

Pulley Diameter	X	Z
8" - 9" (203 mm - 229 mm)	4" (102 mm)	7.25" (184 mm)
10" - 11" (254 mm - 280 mm)	3.75" (96 mm)	7.25" (184 mm)
12" - 13" (305 mm - 331 mm)	3.5" (89 mm)	7.25" (184 mm)
14" - 20" (356 mm - 508 mm)	3.25" (82.5 mm)	7.25" (184 mm)

## NOMENCLATURE

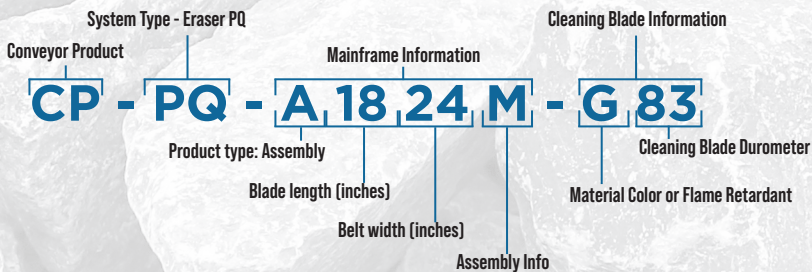

**ARGONICS**  
ENGINEERED POLYURETHANE

520 9th Street • Gwinn, MI 49841  
906.226.9747 f: 906.226.9779  
[www.argonics.com](http://www.argonics.com)



The Argonics Nested Triangle logo, and Eraser PQ™ are trademarks of Argonics, Inc.  
Patents: 6,056,112; 7,441,647; 5,979,638 LIB-CP-PQ-04-01 3/20