

S3Max™

PRIMARY CONVEYOR BELT CLEANING SYSTEM

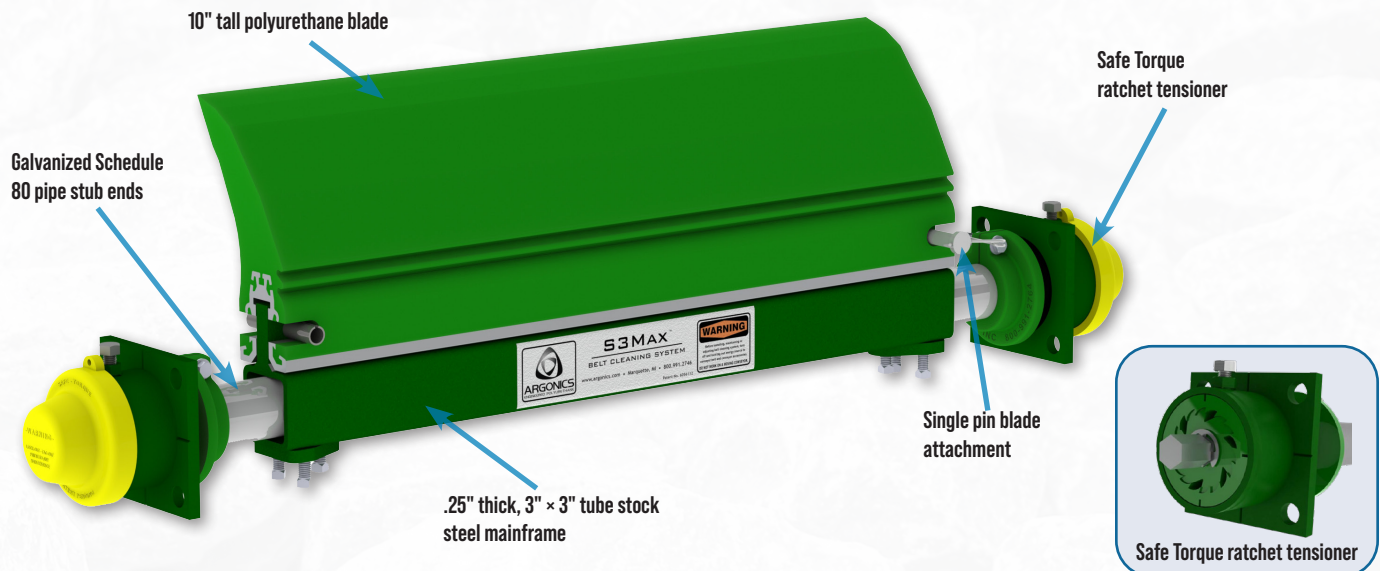





The S3Max is an intermediate system between the Eraser and the Super Eraser that features a 10" tall blade. It is ideally suited for more aggressive applications where a larger blade is required, or those systems with a larger head pulley.



BENEFITS:

- Effective cleaning performance with a 10" (254 mm) tall Raptor blade
- Ideally suited for more aggressive applications
- No rusted springs, hoses, cables, shocks or mud-packed components to deal with
- The Perma-Torque™ tensioner provides uniform cleaning pressure and superior cleaning performance
- Brightly colored, safety yellow end caps seal the Safe Torque™ ratchet from dust and water contamination
- Single pin blade attachment means quick and simple blade change out with less downtime
- A wide variety of configurations as well as complete stainless steel systems are available

BLADES:

-  **N62 Ether**
Normally used for extremely wet applications, sands & fines
-  **FO83 Ester**
MSHA approved Front Line® flame-retardant cleaning blade
-  **R80 Ether**
Good for wet applications with any pH level
-  **RU83 Ester**
Flame retardant, anti-static cleaning blade
-  **G83 Ester**
Our standard, high abrasion-resistant all-purpose cleaning blade
-  **U90**
Good for dry applications with any pH level
-  **B93 Ester**
Our high temperature cleaning blade, up to 250°F (121°C)

SIZING INFORMATION

Dimensions - in. (mm)

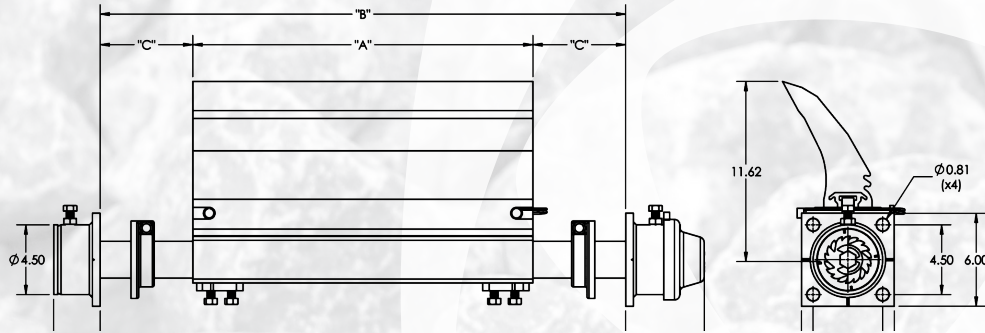

Part Number	A		Min B		Max B		Min C		Max C	
	inches	(mm)	inches	(mm)	inches	(mm)	inches	(mm)	inches	(mm)
CP-S3M-A22M-G83	22.00	(559)	22.50	(572)	38.00	(965)	0.25	(6)	8.00	(203)
CP-S3M-A28M-G83	28.00	(711)	28.50	(724)	44.00	(1118)	0.25	(6)	8.00	(203)
CP-S3M-A34M-G83	34.00	(864)	34.50	(876)	50.00	(1270)	0.25	(6)	8.00	(203)
CP-S3M-A40M-G83	40.00	(1016)	40.50	(1029)	56.00	(1422)	0.25	(6)	8.00	(203)
CP-S3M-A46M-G83	46.00	(1169)	46.50	(1181)	62.00	(1575)	0.25	(6)	8.00	(203)
CP-S3M-A52M-G83	52.00	(1321)	52.50	(1334)	68.00	(1727)	0.25	(6)	8.00	(203)
CP-S3M-A58M-G83	58.00	(1473)	58.50	(1486)	74.00	(1880)	0.25	(6)	8.00	(203)

Notes:

- To get minimum B or C, the shaft collars must be removed.
- For extended tensioner, add 14" (356 mm) to max B and 7" (178 mm) to max C.
- Standard in stock sizes shown above. Other sizes are available, from 22" (559 mm) to 96" (2438 mm).

SPECIFICATIONS

Recommended Belt Speeds
0 - 900 fpm (4.5 m/s)

Pulley Diameter (PD)
Minimum: 24" (610 mm)
Maximum: 48" (1219 mm)

MOUNTING INFORMATION



Pulley Diameter	X	Z
24" - 27" (610 mm - 686 mm)	4.75" (121 mm)	12.75" (324 mm)
28" - 31" (711 mm - 787 mm)	4.5" (114 mm)	12.75" (324 mm)
32" - 48" (813 mm - 1219 mm)	4.25" (108 mm)	12.75" (324 mm)

NOMENCLATURE

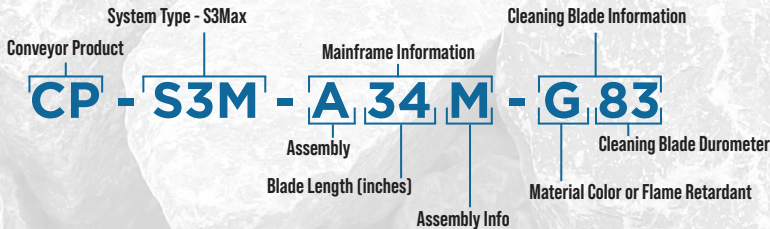

520 9th Street • Gwinn, MI 49841
906.226.9747 f: 906.226.9779
www.argonics.com

