

Super Eraser™

PRIMARY CONVEYOR BELT CLEANING SYSTEM

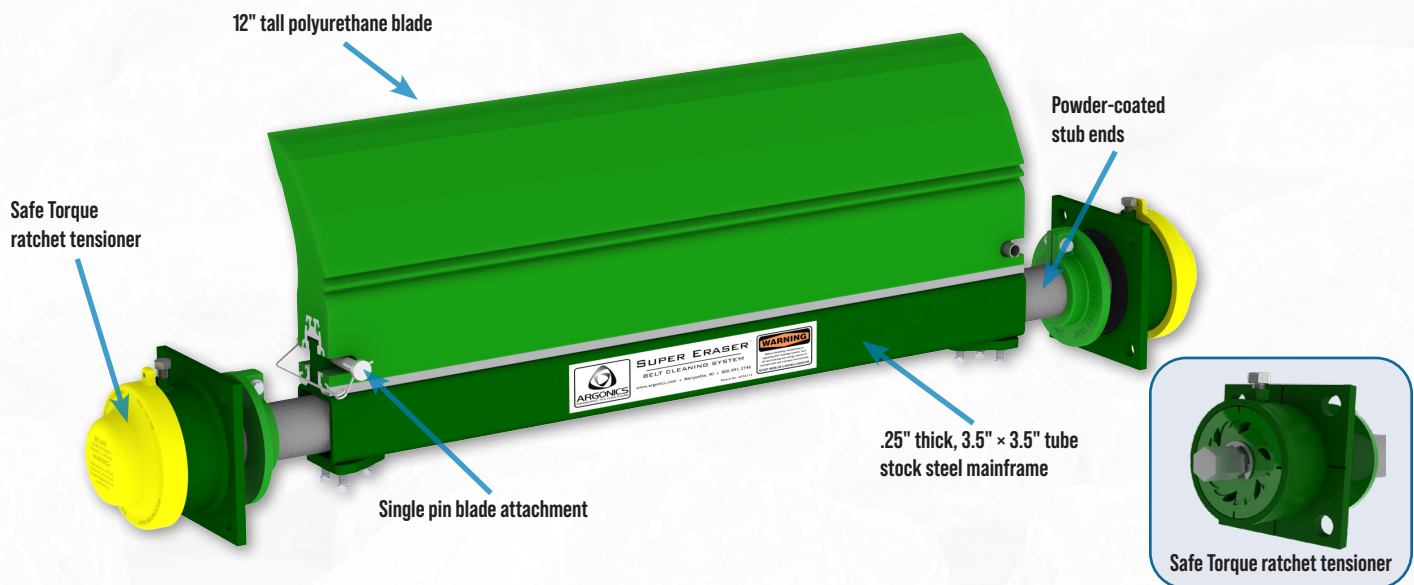





The Super Eraser is a mine duty cleaner. It has a .25" (6mm) thick, 3.5" x 3.5" (89 mm x 89 mm) box steel mainframe and a massive 12" (305 mm) polyurethane blade. It will handle anything you throw at it. If you're dealing with high speed, high tonnage belts, the Super Eraser was built specifically for you.



BENEFITS:

- For use on conveyors with large head pulleys, big loads, harsh conditions and/or fast belt speeds
- Extremely effective cleaning performance with a 12" (305 mm) polyurethane blade and rugged mainframe
- The Perma-Torque™ internal central tensioner is adjustable from 30 to 135 ft-lb (40 to 183 Nm) resulting in uniform cleaning pressure to the conveyor belt
- Compact mounting footprint only protrudes 5.5" (140 mm) from mounting structure
- Safety yellow colored end caps seal the Safe Torque™ ratchet from dust and water contamination
- Single pin blade attachment means quick blade change out with less downtime

BLADES:

-  N62 Ether
Normally used for extremely wet applications, sands & fines
-  FO83 Ester
MSHA approved Front Line® flame-retardant cleaning blade
-  R80 Ether
Good for wet applications with any pH level
-  RU83 Ester
Flame retardant, anti-static cleaning blade
-  G83 Ester
Our standard, high abrasion-resistant all-purpose cleaning blade
-  U90
Good for dry applications with any pH level
-  B93 Ester
Our high temperature cleaning blade, up to 250°F (121°C)

SIZING INFORMATION

Dimensions - in. (mm)

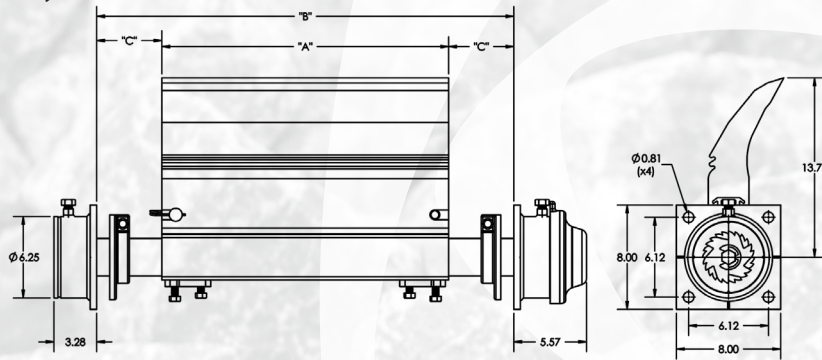

Part Number	A		Min B		Max B		Min C		Max C	
	inches	(mm)	inches	(mm)	inches	(mm)	inches	(mm)	inches	(mm)
CP-SE2-A34D-G83	34.00	(864)	44.50	(1130)	64.00	(1626)	5.25	(133)	15.50	(394)
CP-SE2-A40D-G83	40.00	(1016)	44.50	(1130)	70.00	(1778)	2.25	(57)	15.50	(394)
CP-SE2-A46D-G83	46.00	(1168)	46.50	(1181)	76.00	(1930)	0.25	(6)	15.50	(394)
CP-SE2-A52D-G83	52.00	(1321)	52.50	(1334)	82.00	(2083)	0.25	(6)	15.50	(394)
CP-SE2-A58D-G83	58.00	(1473)	58.50	(1486)	88.00	(2235)	0.25	(6)	15.50	(394)
CP-SE2-A70D-G83	70.00	(1778)	70.50	(1791)	100.00	(2540)	0.25	(6)	15.50	(394)

Notes:

- To get minimum B or C, the shaft collars must be removed.
- Standard in stock sizes shown above. Other sizes are available, from 22" (559 mm) to 120" (3048 mm).

SPECIFICATIONS

Recommended Belt Speeds
0 - 1000 fpm (5 m/s)

Pulley Diameter (PD)
Minimum: 24" (584 mm)
Maximum: 60" (1524 mm)

MOUNTING INFORMATION

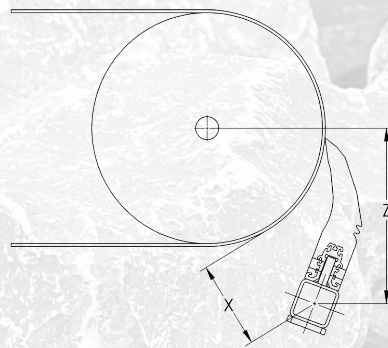

Pulley Diameter	X	Z
24" - 25" (584 mm - 635 mm)	8.5" (216 mm)	15.75" (400 mm)
26" - 28" (660 mm - 711 mm)	8" (203 mm)	15.75" (400 mm)
29" - 31" (737 mm - 787 mm)	7.5" (190 mm)	15.75" (400 mm)
32" - 35" (813 mm - 889 mm)	7" (178 mm)	15.75" (400 mm)
36" - 40" (914 mm - 1016 mm)	6.5" (165 mm)	15.75" (400 mm)
41" - 45" (1041 mm - 1143 mm)	6" (152 mm)	15.75" (400 mm)
46" - 49" (1168 mm - 1245 mm)	5.75" (146 mm)	15.75" (400 mm)
50" - 60" (1270 mm - 1524 mm)	5.5" (140 mm)	15.75" (400 mm)

NOMENCLATURE

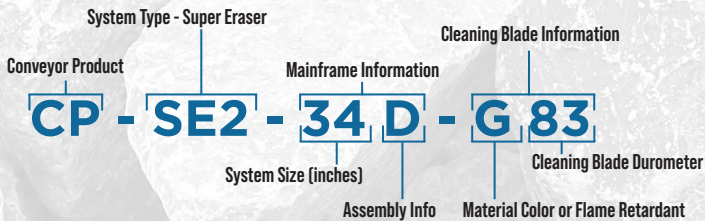

520 9th Street • Gwinn, MI 49841
906.226.9747 f: 906.226.9779
www.argonics.com



The Argonics Nested Triangle logo, Super Eraser™, Perma-Torque™, and Safe Torque™ are trademarks of Argonics, Inc.

Patents: 6,056,112; 7,441,647; 5,979,638 LIB-CP-SE2-04-01 3/20