

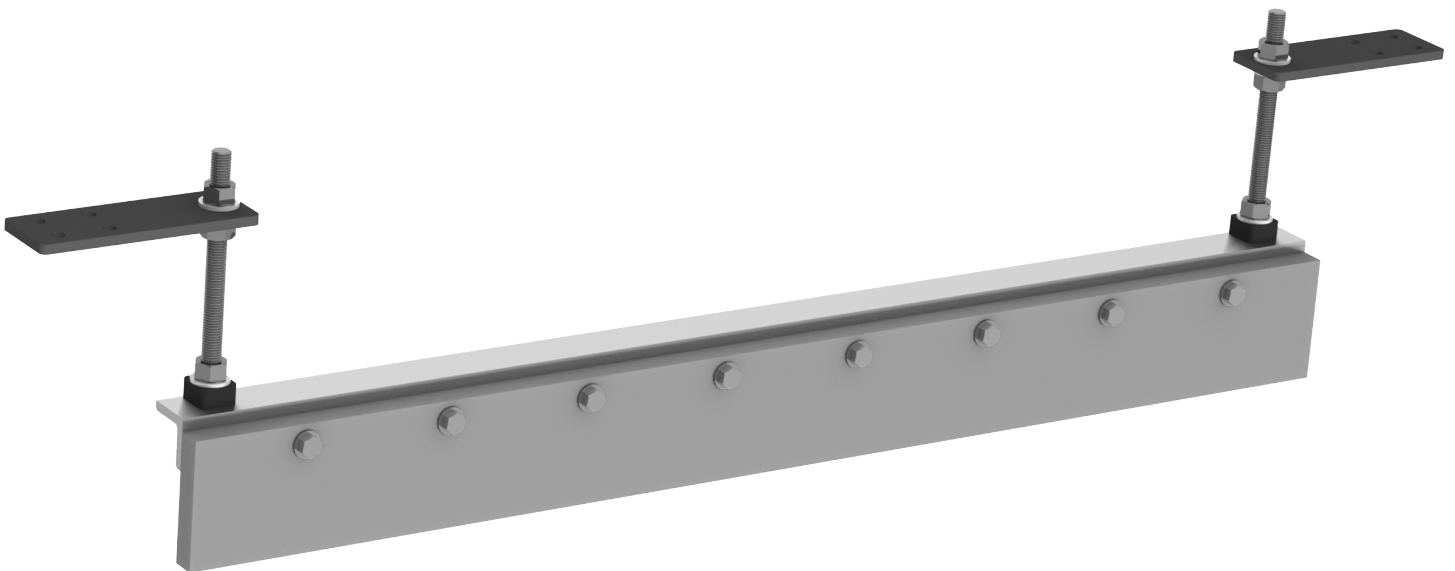

ALUMINUM DIAGONAL PLOW

Conveyor Belt Cleaning System



ALUMINUM DIAGONAL PLOW

⚠ WARNING

Always obey all applicable safety rules.

Be sure all power to the conveyor has been disconnected and controls are locked out.

Installation Tools Required

- Tape measure
- Angle gauge
- Level & straight edge
- Scribe or Chalk

- Welder or Drill
- $\frac{3}{4}$ " End Wrench
- $1\frac{1}{8}$ " End Wrench or Crescent Wrench

Bolts, lock washers and nuts for mounting are not supplied

Assembly Breakdown

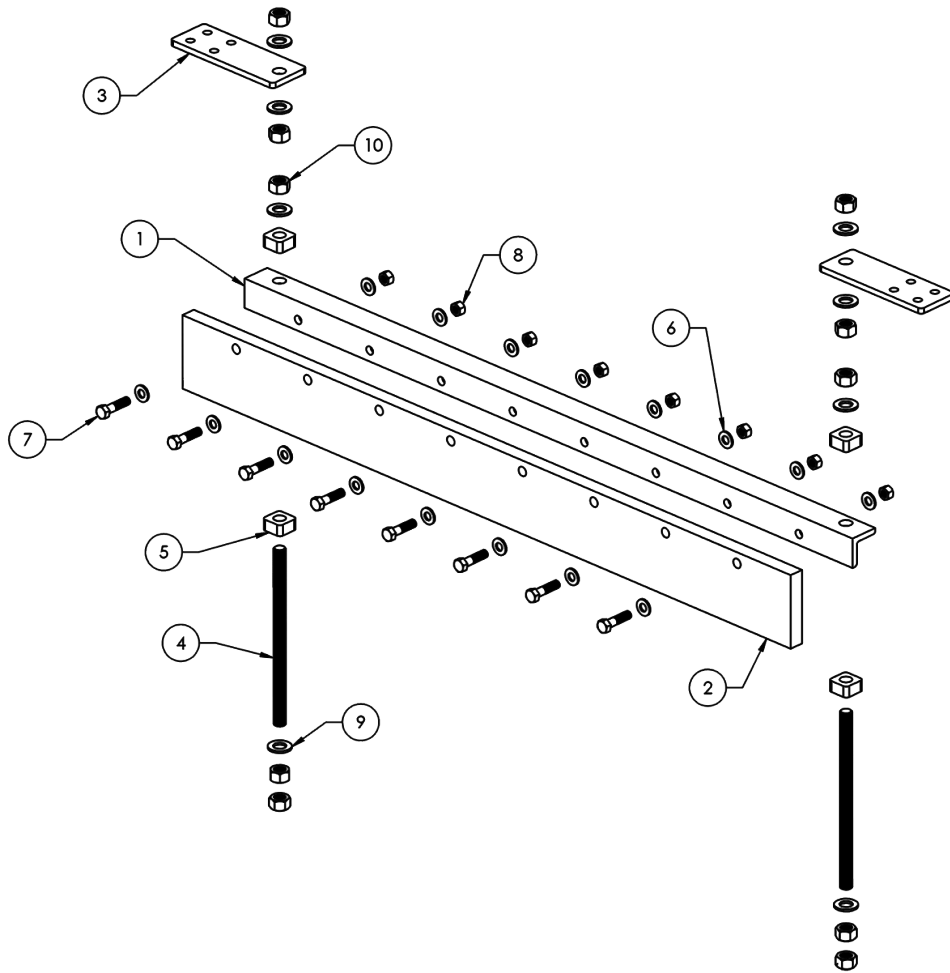

Number	Part Number	Quantity	Description
1	CP-DAP-M"XX"- "XX"	1	Mainframe - see pricing on previous pages
2	CP-DP-15"XX"-G83	1	Blade - see pricing on previous pages
3	CP-DAP-P3838	2	Mounting Bracket
4	CP-DAP-P7512	2	$\frac{3}{4}$ " Threaded Rod, 12"
5	CP-DAP-P7515-B93	4	Urethane Bushing
6	WASH-0.50-F-ZINC	varies	$\frac{1}{2}$ " Flat Washer, Zinc
7	BOLT-0.5X2-NC-ZINC	varies	Bolt, $\frac{1}{2}$ " x 2"
8	NUT-004	varies	Hex Nut $\frac{1}{2}$ "-UNC
9	WASH-0.75-F-SAE-ZINC	8	Washer $\frac{3}{4}$ " Flat - SAE - Zinc
10	NUT-010	10	Hex Nut $\frac{3}{4}$ " Plain

⚠ NOTICE Safety First!

Be sure to follow all manufacturers' directions carefully. Make absolutely sure that all power sources to the conveyor you will be working on have been locked / tagged out before beginning any work.

Step One: Set Up

The Diagonal Plow is packaged disassembled for ease of shipping. There should be three assemblies within the packaging: one mainframe/blade and two adjustment brackets. To complete the assembly of the plow, take the pair of 3/4" hex nuts, the 3/4" washer and one urethane bushing off of the threaded rod for each of the adjustment brackets. Next, place each of the adjustment bracket assemblies into the hole in the mainframe from the top. Replace the urethane bushing, the 3/4" washer and the two 3/4" hex nuts that were previously removed. Adjust the two hex nuts so that the bottom one is flush with the bottom of the threaded rod. Tighten the hex nut (on top of the mainframe) against the urethane bushing and mainframe.

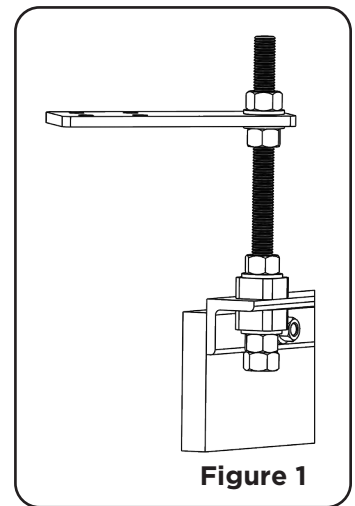

Step Two: Layout

Begin layout by cleaning any debris from the conveyor belt surface where you will be mounting the diagonal plow. Using a 90 degree layout tool, draw a line across the entire width of the belt perpendicular to the belt length (see L1 in figure 2). You may need to draw a partial line and then finish it with a straight edge. This line should be no further than 4 feet and no closer than 2 feet from the tail pulley in order to properly protect the pulley from tramp materials (see figure 3 on next page). If for some reason you can not mount the plow within this area, you must then mount it to the closest available flat return idler, with the distance being no more than 1 foot from the idler.

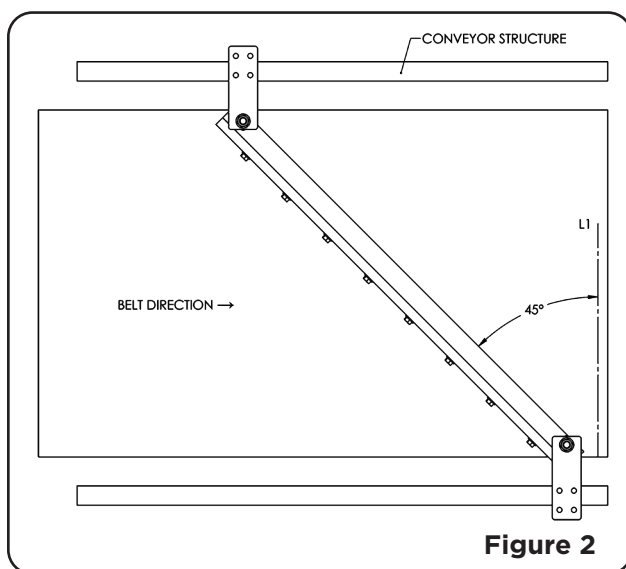

NOTE: The further you place the diagonal plow away from the tail pulley, the more likely your pulley will become susceptible to tramp materials.

The diagonal plow can be installed to discharge to the right or left of the conveyor belt and may be mounted at any angle between 25° and 45°, however we recommend an angle of 45° for proper belt cleaning. Any angle less than 25° and proper cleaning will not occur.

Using an angle layout tool, draw a diagonal line across the entire width of the belt to the angle which you desire using L1 as your reference line (see figure 2 with the reference to 45°). You may need to draw a partial line and then finish it with a straight edge.

Installation

Step Three: Mounting

You will need the assistance of another person to properly mount this Diagonal Plow. Place the complete system on top of the belt surface and be sure to stand the plow upright on its blade. Make sure that the plow is parallel with the diagonal line you drew in Step 2 and that the blade is flush to the conveyor belt edge or extends beyond the belt edge on both sides. You may have to lessen your angle in order to get the plow into this position (see figure 2).

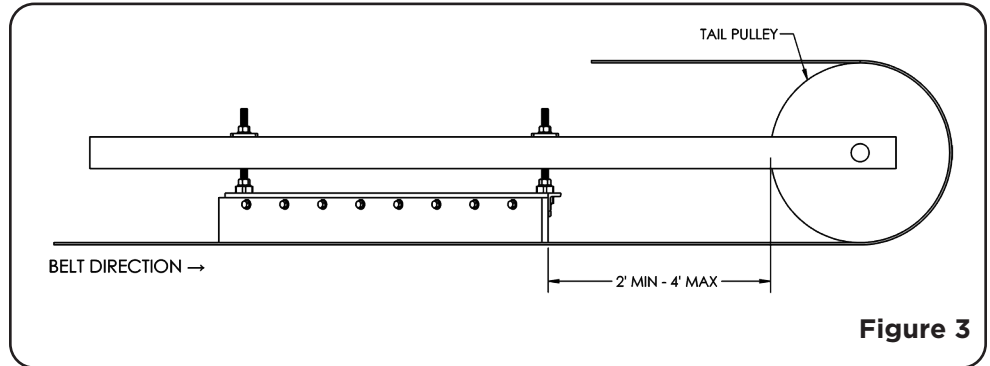

Adjust the top two hex nuts so that the mounting bracket is flat against the mounting structure. If bolting, trace the outline and hole locations of the mounting bracket. Drill holes to accept 1/2" bolts. If welding, four stitch welds will be sufficient. Once the bracket is secure to the structure, tighten all of the hex nuts on the adjustment brackets. Run the belt and check to make sure that the plow runs smoothly and cleans effectively. Make any necessary adjustments by raising or lowering the two hex nuts against the mounting bracket.

Installation is now complete.

**ARGONICS**
ENGINEERED POLYURETHANE
520 9th Street • Gwinn, MI 49841
906.226.9747 800.991.2746 f: 906.226.9779
www.argonics.com

