

VALVE BOX COVER

Installation Guide

Safety First!
Be sure the area you are working in is safe.

Step 1. Remove existing cover.

Step 2. Thoroughly clean out the top portion where the cap will seat on the existing cast iron box.

Step 3. Drop in spacer along with the Argonics Inc. elastomeric polyurethane valve box cover. (See Fig. 1)

Step 4. Push cover down completely to seat in the cast iron box.

Step 5. Check height. The cover should sit just below (1/16" – 1/8") the existing cast iron box. (See Fig. 2).

If cover sits higher than the existing cast iron box, remove cover and take out the spacer.

**Different size spacers are available upon request*

Step 6. Replace cover and push down completely to seat in box.

FIGURE 1

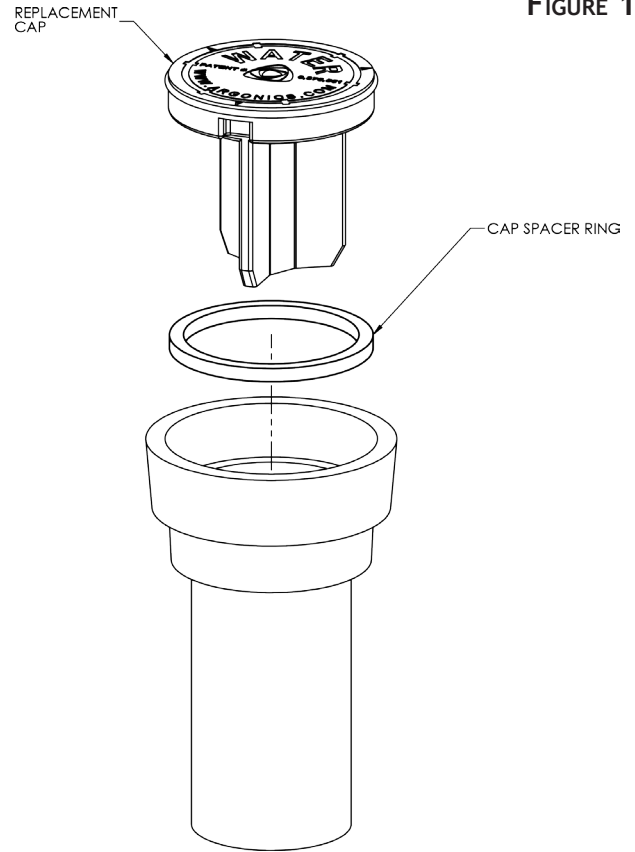

TOP OF CAP SHOULD
BE 1/16" TO 1/8"
BELOW EXISTING BOX

FIGURE 2

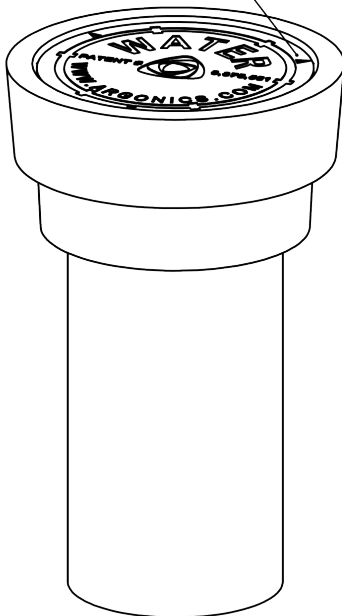

INSTALLATION IS NOW COMPLETE!

