

BELT CLEANER APPLICATION GUIDE

Application Data Sheet

Customer Information

Company: _____

Contact: _____

Address: _____

City: _____

State: _____ ZIP: _____

Phone: _____

Email: _____

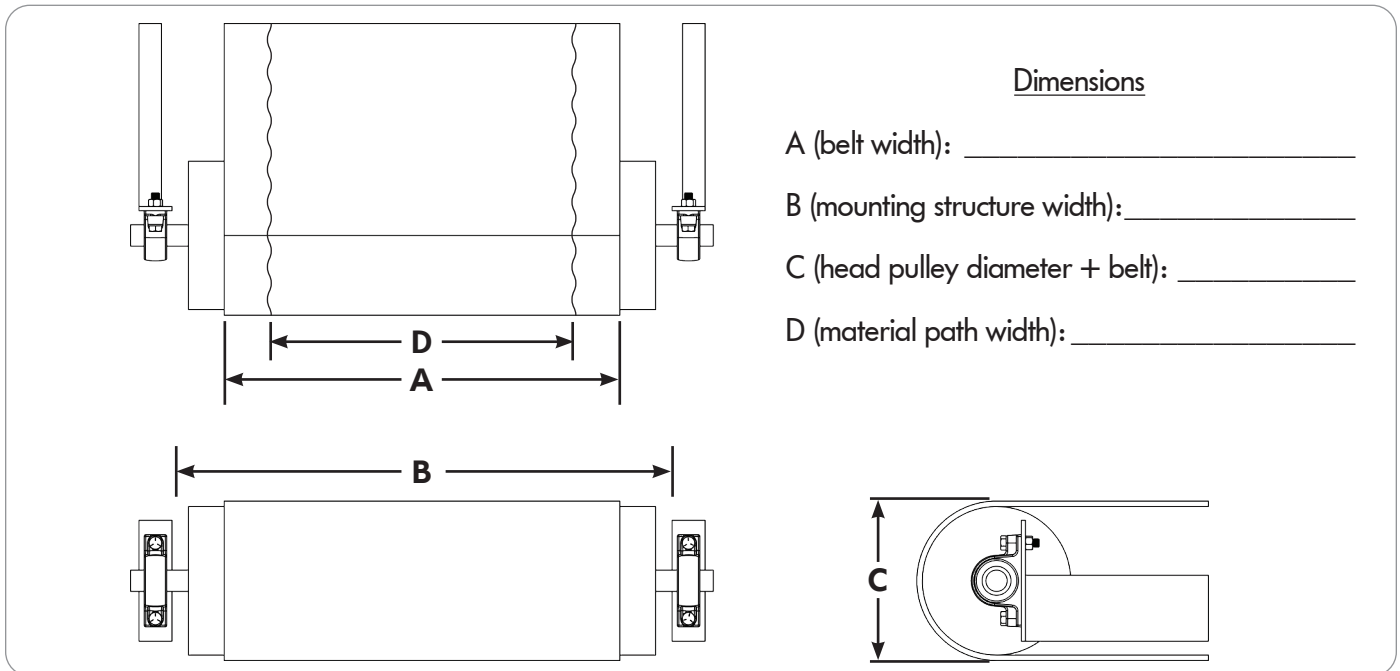

Conveyor Information

Belt speed: _____

Type of splice: Vulcanized Mechanical

If mechanical, is belt skived? Yes No

Reversible conveyor? Yes No

Crowned pulley? Yes No

Existing cleaner type: _____

Blade wear life: _____

Past history of other cleaners tried: _____

Failure point of that cleaner: _____

Materials Information

Material handled: _____

Particle size: _____

Is material abrasive? Yes No

Shape (round, crushed, blasted, etc.): _____

Moisture content (slurry, dry, damp, etc.): _____

Are elevated temps. involved? Yes No

If yes, what temp.? _____

Amount (tons per hour): _____